

OPERATION MANUAL

92-1237 Rev. 241121
Model 603SBCM Clamshell



ABOUT TRI TOOL TECHNOLOGIES



At Tri Tool Technologies, we are committed to your success through relentless innovation and powerful partnership. We insist on developing tools and equipment that exceed your expectations of performance, precision, safety, and durability. As a full-service engineering firm, we are here to support you every step of the way.

For more information on engineered solutions, products, and trainings, visit tritool.com or contact our engineers at +1 (916) 288-6100.

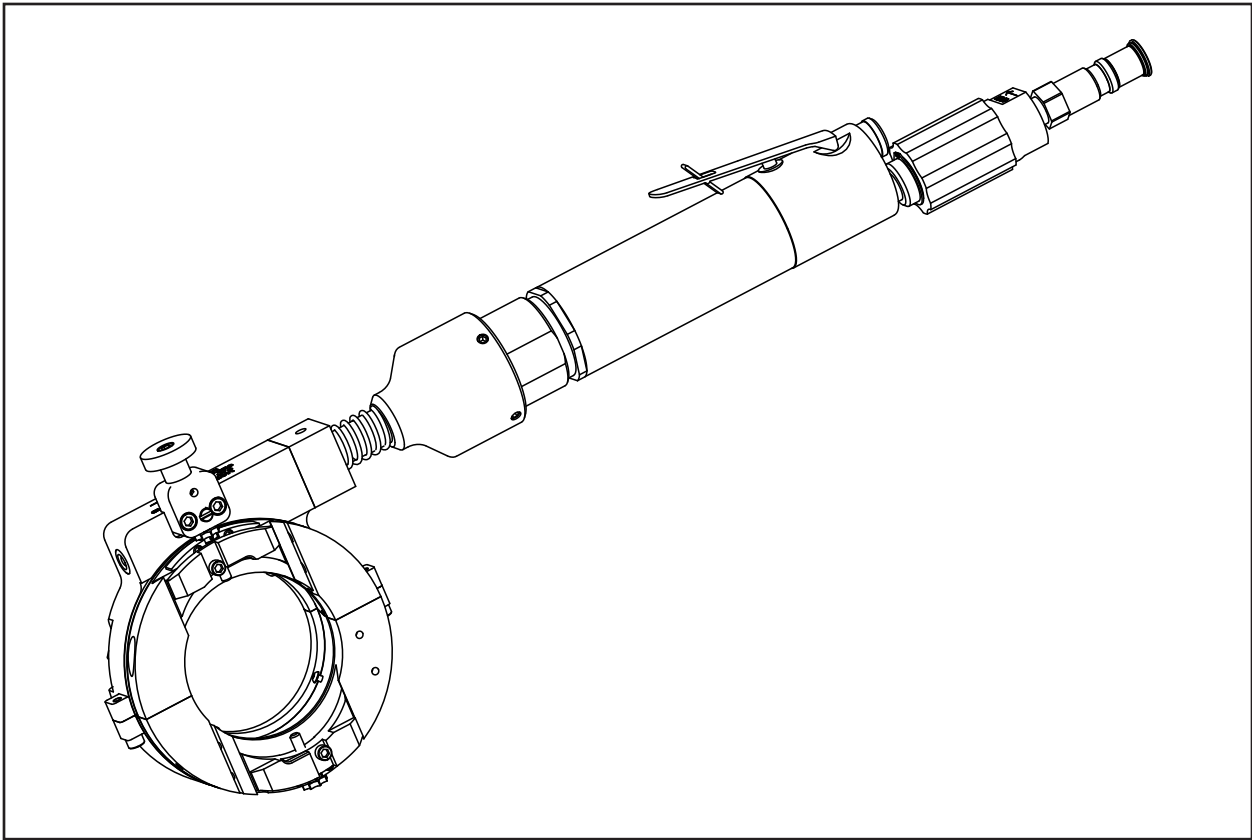

TABLE OF CONTENTS

TRI TOOL TECHNOLOGIES WARRANTY	2
TOOL BIT RESHARPENING POLICY	3
ABOUT THE MANUAL	4
SAFETY PRECAUTIONS	6
GENERAL DESCRIPTION	8
SPECIFICATIONS	9
COMPONENT OVERVIEW	10
SETUP AND INSTALLATION	11
OPERATION	14
CUTTING SPEEDS AND FEEDS	16
TOOL BITS	17
COLLETS	18
MAINTENANCE	19
STORAGE	24
TROUBLESHOOTING	25
ACCESSORIES	27
ILLUSTRATED PARTS BREAKDOWN	28

Tri Tool Technologies Warranty

LIMITED WARRANTY: All products manufactured by Seller are warranted to be free from defects in materials and workmanship under normal use. The period of this warranty shall be three years from the date of shipment for all products, except for welding and Non-Standard Products which shall be one year from the date of shipment. The Buyer shall bear all shipping, packing and insurance costs and all other costs to and from a designated repair service center. All return goods must be authorized in advance and communicated upon issuance of a Return Material Authorization (RMA) by Seller. The product will be returned to the Seller accompanied by a RMA number and associated paperwork, freight prepaid and billed to the Buyer. This warranty is not transferable and will not apply to tool bits or other consumables, or to any Goods to have been (i) mishandled, misused, abused or damaged by Buyer or any third party; (ii) altered without the express permission in writing by Seller, (iii) repaired by a party other than Seller without Seller's prior written approval; or (iv) improperly stored, installed, operated, or maintained in a manner inconsistent with Seller's instructions. This warranty does not apply to defects attributed to (i) normal wear and tear or (ii) failure to comply with Seller's safety warnings.

No warranty for any parts or other supplies provided to seller by buyer, whether or not they are incorporated into goods. Goods supplied by seller which are designed or manufactured by a third party are subject strictly to the third party's warranty for those goods. Seller makes no warranty and disclaims all statutory or implied warranties for these goods, including the implied warranties of merchantability, freedom from patent infringement and fitness for a particular purpose.

Neither this warranty nor any other warranty, expressed or implied, including implied warranties of mechanical ability, fitness for a particular use, or merchantability, shall extend beyond the warranty period. No responsibility is assumed for any incidental or consequential damages. Some states do not allow limitations on how long an implied warranty lasts and some states do not allow the exclusion or limitations incidental or consequential damages, so the above limitation of exclusion does not apply to all Buyers. This warranty gives the Buyer specific legal rights. Other rights vary from state to state.

Warranty Claims and Remedies

Buyer must promptly notify Seller in writing during the applicable warranty period, of any defective Goods covered by Seller's warranties under the Limited Warranty section herein, and no later than fifteen (15) calendar days after discovery of the defect. Seller has no obligation to honor any warranty claim made after the expiration of the warranty period. However, despite the expiration of the warranty period, Seller, at its reasonable discretion, may accept warranty claims submitted up to fifteen (15) calendar days after the expiration of the warranty period provided that Buyer provides Seller with credible and persuasive documentary evidence that the defect was discovered during the warranty period. No warranty claims submitted after this fifteen (15) day calendar period will be considered by Seller.

Buyer's notice of a defective Goods must identify the specific Goods affected, and the nature of the defect. It is required when returning the defective Goods, that it is suitably packed, fully insured, and transportation and insurance prepaid in accordance with instructions issued by Seller. Seller, at its sole option, will either repair or replace any Goods authorized for return to Seller. Such repair, replacement, or credit shall be Buyer's sole remedy for defective Goods. Buyer must promptly provide Seller with all information requested regarding the identified defect.

If the defect claimed by Buyer cannot be reproduced or otherwise verified by Seller, the Goods will be returned to Buyer unmodified at Buyer's expense.

The warranty period for repaired or replaced Goods shall be (i) ninety (90) days or (ii) the unexpired portion of the original warranty period. Under no circumstances is Seller liable for recall, retrieval, removal, dismantling, re-installation, redeployment, or re-commissioning of any defective Goods or any costs associated therewith.

Tool Bit Resharpener Policy

Buyer is required to check all tool bits prior to returning and ensure they are packaged well for shipment. The price structure is available from the Seller's sales coordinator. Seller cannot resharpen badly gouged, chipped, or broken tool bits. Seller will return tool bits that are not suitable for resharpening with the tool bits that were resharpened upon Buyer's request. Buyer is responsible for all shipping charges to and from Seller.



1. ABOUT THE MANUAL

Copyright

©Copyright Tri Tool Technologies. Proprietary property of Tri Tool Technologies. No reproduction, use, or duplication of the information shown hereon is permitted without the express written consent of Tri Tool Technologies.

Disclaimer

The instructions and descriptions in this manual were accurate when the manual was written. However, the information in the manual is subject to change without notice. Check for updated information before you start any job. The Tri Tool Technologies web site has the most current information.

Do not operate or work on this equipment unless you have read and understood the instructions in this Manual. Failure to follow the instructions or follow the safety instructions could result in serious injury or death. This manual describes conditions and hazards that are common and anticipated during equipment operation. No manual can address all conditions which may occur.

Safety Symbols

The manual may contain one or more safety symbols. These symbols and the associated text warn you of potentially hazardous conditions. Examples of the safety symbols and the associated text follow:



DANGER

DANGER: Indicates a hazardous situation that, if not avoided, will result in serious injury or death.



WARNING

WARNING: Indicates a hazardous situation that, if not avoided, could result in serious injury or death.



CAUTION

CAUTION: Indicates a hazardous situation that, if not avoided, could result in minor or moderate injury, or cause property damage.



GLASSES

SAFETY GLASSES: Indicates a hazardous situation that requires the use of safety glasses.



HOT SURFACE

HOT SURFACE: Indicates a hazardous situation that hot surfaces may be present.



GLOVES

GLOVES: Indicates a hazardous situation that requires gloves.



SHOCK HAZARD

ARC FLASH & SHOCK HAZARD: High voltage. Entry by authorized personnel only. Appropriate PPE and tools required when working on this equipment.



READ MANUAL

READ MANUAL: Read manual before use, refer to manual for Tri Tool Technologies machine being used.



DISCONNECT FROM POWER

DISCONNECT FROM POWER: Disconnect main plug from electrical outlet before performing all maintenance.

2. SAFETY PRECAUTIONS

In General

Use standard safety equipment such as: hard hats, safety shoes, safety harnesses, protective clothes, and other safety devices when appropriate.

Operate this tool only in accordance with specific operating instructions.



WARNING: Do not override the deadman switch on the power unit. Locking down, obstructing, or in any way defeating the deadman switch on the power drive unit may result in serious injury.

Personal Protective Equipment

Use standard safety equipment such as: hard hats, safety shoes, safety harnesses, protective clothes, and other safety devices when appropriate.

Wear safety glasses.

Do not wear loose clothing or jewelry.

Wear nonskid footwear.

Put long hair in a cap or a net to make sure hair does not get tangled in equipment.

Personnel

Only personnel who are trained or are being trained may operate the equipment.

Keep the operation manual available where the equipment is used.

The operator must read the operation manual before using the equipment.

The equipment must be operated in accordance with the manual information.

The operator must follow the safety precautions in this manual and good engineering practices to reduce the risk of injury.

Before using the equipment, the operator must ensure that all safety messages on the equipment are legible.

Work Area

Keep the work area clean.

Keep the area well lit.

Keep items such as electrical cords, cables, rags, rigging straps, away from rotating equipment.

Do not use power-cutting tools in the presence of flammable liquids and gases.

Do not let visitors or untrained personnel near tools that are in use.

Ensure all observers wear eye protection.

Keep proper footing at all times.

Area Equipment

Secure the pipe with clamps, vises, chains or straps.

Ensure that both sides of the pipe at the cut site are fully supported so that the pipe will not move after the cut is completed. Long lengths of pipe may be under load and the separation of the pipe can release pressure. This pressure can cause both sides of the pipe to move.

Tool Care

Keep tools in good operating condition. Sharp tool bits perform better and are safer than dull tool bits.

Do not use damaged tools. Always check your tools for damage especially if a tool has malfunctioned, been dropped or hit, check it for damage.

Before you start operating the equipment, do no-load tests and feed function checks.

Tool Use

Use the right tool and tool bit for the job. Contact Tri Tool Technologies to help with your application.

Keep the tool bits fully engaged in the tool bit holders. Loose bits are sharp and can cause cuts or punctures.

Disconnect power supply during setup and maintenance. Use all 'Stop' or Shut off' features available when changing or adjusting tool bits, maintaining the tool, or when the tool is not in use.

Remove adjusting keys and wrenches before applying power to the equipment. Check the tool before turning it on to make sure that all keys and wrenches have been removed.

Do not force tools. Tools and tool bits function better and safer when used at the recommended speeds.

Do not reach into rotating equipment.

Do not reach into the rotating head stock to remove chips, to make adjustments, or to check the surface finish.

Handle chips with care. Chips have very sharp edges and are hot. Do not try to pull chips apart with bare hands.

Store tools properly. Disconnect tools from the power source, remove the tool bits, and store in a safe place.

3. GENERAL DESCRIPTION

The 603SBCM Low Profile Clamshell is a split-frame pipe lathe for severing and beveling inline pipe with a range of 1 1/4" pipe through 3" tube with minimal radial and axial clearances.

Easily adjustable precision bearing surfaces preload and stabilize the rotating head to provide long life, low maintenance, stability, and precision.

The Clamshell splits into two halves for mounting on closed loop systems. All parts are secured to the two halves to avoid loss of parts and provide maximum ease of handling.

The machine is equipped with self-centering Collets.

Dual dovetail Tool Modules with auto-feed sprockets and adjustable gib provide maximum maintainability, life and operator safety with minimum operator training.

The auto-feed star sprockets provide .003" (.08mm) of radial feed per revolution for a controlled depth of cut.

Drive worm, worm gears, and bearing surfaces are covered for operator safety.

Operator controls are away from the rotating headstock for safety.

Modular design concepts provide quick, easy maintenance and maximum versatility in drive and tooling options.

Detachable Bayonet-type motor provides maximum handling ease and low axial clearance. A flex drive shaft is also available to bring the motor away from the tool.

4. SPECIFICATIONS

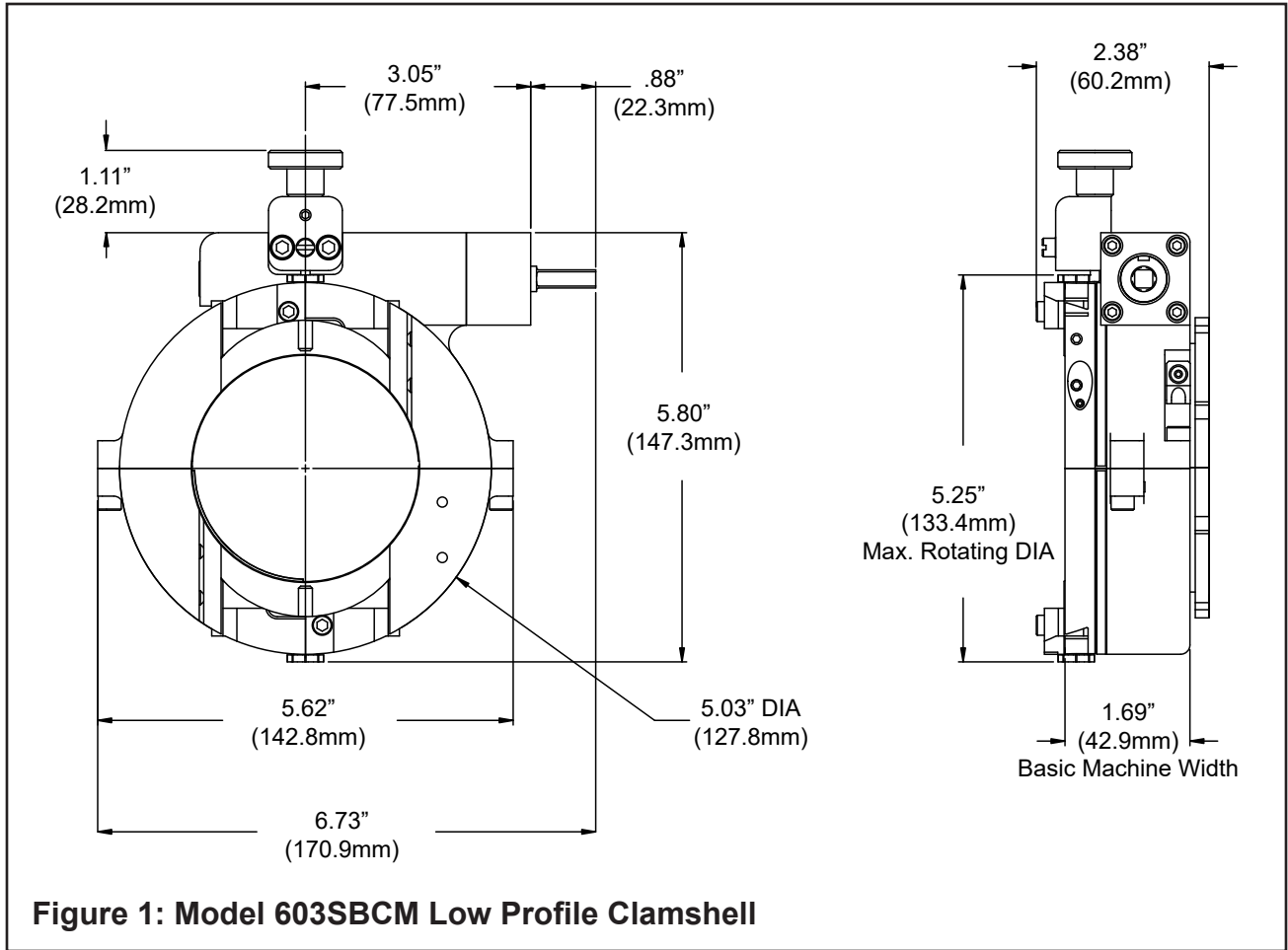

Figure 1: Model 603SBCM Low Profile Clamshell

Weight

Basic Machine	6.2 lbs (2.81 kg)
Motor	5.4 lbs (2.43 kg)

Main Drive Gear

Worm Drive

Motor Mount

Bayonet-type

Clamping

Collet-type

Pipe Size Range

1 1/4" pipe through 3" tube

Tool Bit Feed Rate

.003" (.08mm) per revolution

Mounting

Manual saddle clamping system

5. COMPONENT OVERVIEW

Clamshell

The Clamshell is the main part of the machine. Contained within it is the Collet that secures the Clamshell to the pipe, two Tool Bit mounting blocks and feed mechanisms, a Tripper Pin that is engaged or disengaged to either feed or not feed the Tool Bits into the pipe, and the drive shaft to rotate the machining head with mounting provisions for the air motor. When engaged, the Tripper Pin causes the Tool Bit to advance .003" (.08mm) every revolution of the machine.

Motor

The power to rotate the machining head comes from the motor. The motor can either be directly attached to the Clamshell or connected to it through a flexible shaft. A spring energized twist-lock coupling connects these components together. There is a flow control valve on the air motor and rheostat on the electric motor for controlling its speed.

Flexible Drive Shaft

If space restrictions in the working area do not allow the air motor to be directly attached to the Clamshell, then the flexible drive shaft can be used. The flexible drive shaft is 18" (457.2mm) long and has a spring-energized twist-lock coupling at each end.

Tool Bits

The rotating head of the Clamshell has holders that allow two Tool Bits to be used simultaneously. There are a number of Tool Bits designed for use with this machine. Tool Bit selection depends on what kind of cut is being made. Refer to TOOL BITS section for information about Tool Bit selection.

- A #8-32 hex socket cap screw is used to secure a Tool Bit to the Tool Holder.
- A 9/64" hex wrench is used to remove the cap screw for Tool Bit replacement.

Collets

Four wedge-type Collet pieces are used as a set in the Clamshell to secure it to the pipe. A Collet set is specially sized to match the size pipe being machined. Refer to COLLETS section for the correct Collet P/N to use. Each Collet piece is secured to the Clamshell with a #4-40 hex socket button head cap screw. A 1/16" hex wrench is used to remove the cap screw for Collet piece replacement.

6. SETUP AND INSTALLATION

Hand Tools

- Feed Sprocket Driver
- 9/64" hex wrench for Tool Bit screws
- 5/32" hex wrench for Clamshell screws
- Spanner wrench and torque wrench for Collet nut
- Ratchet wrench and 1/4" square socket for drive shaft
- 1/16" hex wrench for Collets
- 3/32" hex wrench for Tool Modules adjustment screws
- 7/64" hex wrench for bearing locking screws
- 5/64" hex wrench for bearing adjustment screws

Setup

1. Check, clean and lubricate the tool. Use EP grease on sliding surfaces and oil, 10-weight or less, on all other surfaces.
2. Configure the Clamshell for the pipe size being machined using the following procedure:
 - Determine the size of the pipe to be machined.
 - Refer to COLLETS section to determine the Collet set to use.
 - Determine what size Collet is installed in the Clamshell.
3. If the Collet needs to be replaced, use a 1/16" hex wrench to remove the button head cap screw that secures them in the Clamshell. It may be necessary to split the Clamshell in two to accomplish this.
4. Attach the replacement Collet pieces to the Clamshell. Orient the Collet pieces so that the thick side is toward the Collet nut threads. Tighten the button head cap screws so the Collet is retained but moves freely.

Install the Tool Bits

1. Refer to TOOL BITS section for Tool Bit sizes.
2. Use a #8-32 socket head cap screws to install the Tool Bits into the Tool Blocks.
3. Use a 9/64" hex wrench to tighten the socket head cap screws.
4. Use the sprocket driver to fully retract the two Tool Blocks.

5. Ensure that the following are available:
 - Air supply, 32 CFM at 90 PSI
 - Lube oil added at 2 to 4 drops per minute.
 - Cutting fluid, if permitted (cutting speeds will need to be reduced if no cutting fluid is used).

Install the Clamshell

If it is possible to install the assembled tool over the end of the pipe go to the “Secure the Clamshell to the Pipe” section below.

If it is not possible to install the assembled tool over the end of the pipe, use the following procedure.

NOTE: Ensure Tool Blocks are fully retracted before proceeding.

Split the Tool and Reassemble It Around the Pipe

1. Remove the Collet nut.
2. Use the ratchet wrench on the drive shaft to line up the two halves of the rotating gear portion of the machine with the stationary housing portion making sure the top of the cap screws are inline of each other.
3. Unscrew the four (4) #10-24 cap screws that hold the two halves together. Note that the screws' location does not allow them to fall out, even when fully retracted. The two halves should easily separate from each other.
4. When separating the Clamshell, loosen the gear splitline screws first. When reassembling the Clamshell, tighten the housing splitline screws first.
5. Ensure the mating surfaces on both halves of the Clamshell are clear of any dirt or debris.
6. Position the two halves on the pipe, mate them together, and use 5/32” hex wrench to tighten the four (4) #10-24 cap screws.
7. Place the two halves of the Collet nut together around the pipe, screw it into the Clamshell, but do not tighten it.

Secure the Clamshell to the Pipe

1. Position the Clamshell on the pipe so that the Tool Bits cut in the desired location. Allow enough clearance for the air motor. Use the flexible drive shaft if space for the air motor is not available.
2. Tighten the Collet nut with the spanner wrench and hold the machine in place with the torque wrench. Verify that the Clamshell is securely clamped to the pipe.

Set the Tool Bit Position

The Tool Bit will move .025" for one full turn of the feed sprocket.

1. Use the feed sprocket wrench to lower the severing Tool Bit until it touches the pipe.
2. Turn the wrench in the opposite direction until the backlash in the feed screw is removed. A slight increase in the effort required to turn the wrench will be felt but the Tool Bit will not move.
3. Raise the severing Tool Bit three (3) turns of the feed sprocket. When cutting 1" or oversized pipe, this may not be possible. Turn the wrench in the opposite direction until the backlash in the feed screw is removed.
4. Align the feed sprocket so two opposing teeth are in line with the pipe.

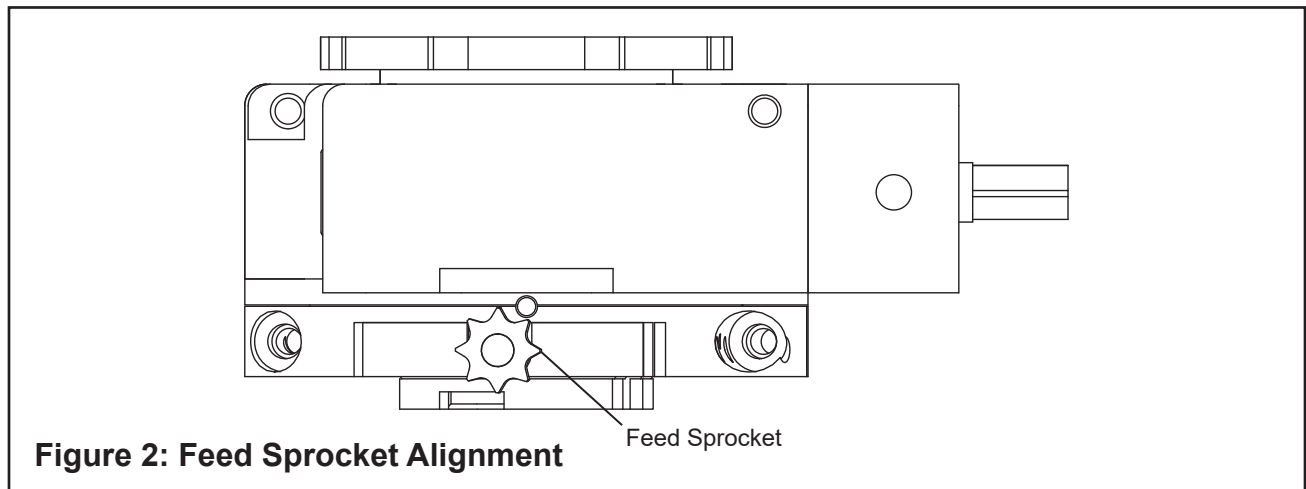

5. Repeat these steps for the beveling Tool Bit, except raise it three and one-half (3 1/2) turns off the surface of the pipe.
6. With the Tripper Pin disengaged, use the ratchet wrench to slowly rotate the head.
7. Verify that both Tool Bits are able to clear the diameter of the pipe without contacting anything. If it appears that either Tool Bit will contact the pipe surface, stop the head and make adjustments (raising both Tool Bits by the same amount, removing the interference, repositioning the machine, etc).
8. With the Tripper Pin engaged, slowly rotate the head one revolution. Observe that the Tripper Pin moves each of the feed sprockets correctly.

Attach the Motor

1. Attach the motor to the Clamshell either directly or by the flexible drive shaft.
2. Connect the air supply to the air motor (if using the air motor).

7. OPERATION



WARNING: Do not override the deadman switch on the power unit. Locking down, obstructing, or in any way defeating the deadman switch on the power drive unit may result in serious injury.



CAUTION: When an installed pipe is severed, it may move. Secure the pipe on both sides of the sever line to decrease the risk of personal injury and equipment damage.

Using the Tool Bit

1. Engage the Tripper Pin to begin feeding the Tool Bit into the pipe. Each Tool Bit will be lowered into the cut .003" every time it passes the Tripper Pin, if the Tripper Pin is engaged.
2. Slowly run the Tool Blocks around the pipe and verify Tool Bit positioning and clearance.
3. Increase the speed of the motor to full speed.
4. Watch the cutting action as the Tool Bits begin cutting the pipe, make sure everything is normal. If looseness or another problem is seen, stop the machine and fix the problem before continuing.
5. Apply cutting fluid, if applicable to the application.
6. Monitor the temperature of the body of the tool. If it becomes excessively hot, the main bearing is too tight and requires adjustment (refer to "Adjust the Main Bearing" in the MAINTENANCE section).
7. If the chip tangles in the head, disengage the Tripper Pin for two or three revolutions.
8. Stop the machine and remove the chips.

Remove the Tool From the Pipe

1. Using the feed sprocket driver, retract the Tool Bits until they are clear of the pipe surface.
2. Remove the tool from the pipe.
 - If the machine must be disassembled to remove it from the pipe, do the following:
 - Remove the motor and flexible drive shaft (if present).
 - Use the ratchet wrench to rotate the head until the splitlines of the head and the Clamshell match.
 - Retract the Tool Bits.
 - Loosen the Collet nut using the spanner wrench and torque wrench.
 - If the Clamshell must be split to remove the tool from the pipe, do the following:
 - Remove the Collet nut.
 - Unscrew the four (4) #10-24 cap screws holding the two halves of the Clamshell together using the 5/32" hex wrench.
 - The cap screws will not fall out of the Clamshell when fully unscrewed.
 - Remove the two halves of the tool from the pipe.
3. Unless the tool is going to be immediately installed on another pipe location, reassemble the two halves of the Clamshell and tighten the four (4) screws to 5 to 7 ft-lbs.
4. Reinstall the Collet nut.
5. If the tool is going to be used immediately for another cut, allow the Clamshell to cool before beginning the next cut.

8. CUTTING SPEEDS AND FEEDS

Use 200 surface inches per minute (5080 surface millimeters per minute) for:

- Stainless steels in general when no coolant is allowed, all heavy-wall tube and some chrome/molybdenum steels.

Use 250 surface inches per minute (6350 surface millimeters per minute) for:

- Mild steels and some thin-wall stainless steels when coolants are permitted and applied.

Use 300 surface inches per minute (7620 surface millimeters per minute) for:

- Aluminum and some thin-wall mild steel and tube with coolants.

9. TOOL BITS

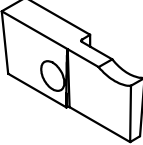
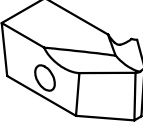
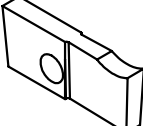
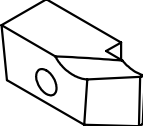
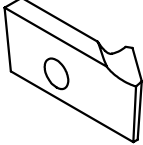
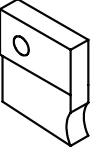
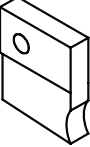
Sever Lead		99-5941C4	
Double Bevel	37 1/2°	99-5942C4*	
Use with 99-5941C4	42 1/2°	99-6003C4*	
	47 1/2°	99-6004C4*	
Sever Trail		99-5943C4	
Use with 99-5941C4			
LH Single Bevel	42 1/2°	99-5999C4*	
Use with 99-5941C4	47 1/2°	99-5999C4*	
RH Single Bevel	37 1/2°	99-5990C4	
Use with 99-5941C4	42 1/2°	99-6001C4	
	47 1/2°	99-6002C4	
Socket Weld Inside		99-5997C4	
Socket Weld Outside		99-5998C4	

*Requires 33-2930 SCREW, CAP, #8-32 X 5/8" SS

**NOTE: A 'Right Hand Bevel' is on the same side of the cut as the 603SBCM.
A 'Left Hand Bevel' is on the opposite side of the cut from the 603SBCM.**

10. COLLETS

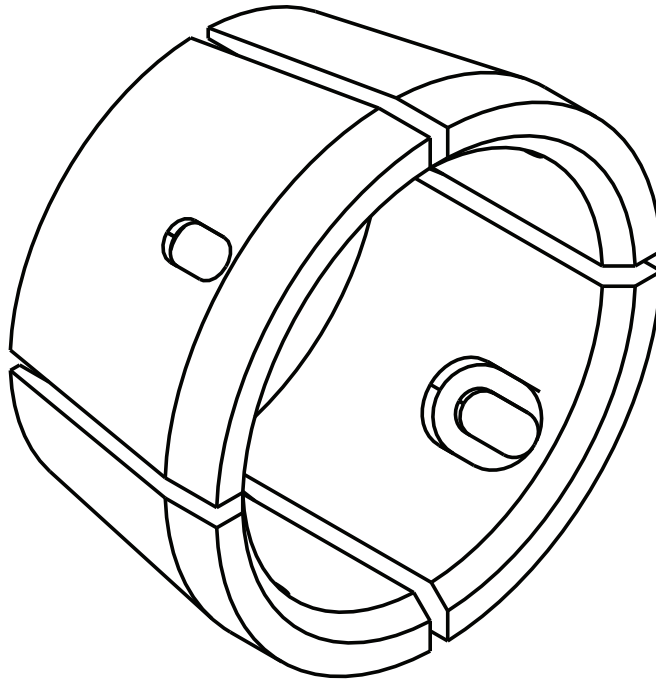

Pipe Size	DIA Decimal	DIA Metric	Collet P/N
2 1/2"	3.000"	76.2mm	30-2939
	2.875"	73.0mm	30-3132
	2.680"	68.1mm	30-3133
	2.480"	63.0mm	30-2947
2"	2.375"	60.3mm	30-2948
	2.000"	50.8mm	30-3134
	1.920"	48.8mm	30-3135
1 1/2"	1.900"	48.3mm	30-3162
1 1/4"	1.660"	42.2mm	30-3161
	1.500"	38.1mm	30-3136

11. MAINTENANCE

General Maintenance Information

This section describes general maintenance procedures that the operator can do. Only qualified personnel may do other maintenance and repair procedures.

Keep all equipment in good working condition and inspect it regularly.

If the equipment is not in good working condition, promptly repair it or withdraw it from service.

The air supply for the Model 603SBCM requires an adequate filter/lubricator (FRL) to be used. The motor warranty is void if damage occurs from contaminated air or lack of lubrication.

Use only Tri Tool Technologies-supplied replacement parts for repairs.

Service Intervals

Before Each Use

- Adjust the Tool Module slides.
- If the Tool Block collects debris, clean the Tool Block and the feed screws before each cutting operation.

Daily

- Inspection all parts for damage due to chips, impact or improper use.
- Repair or replace broken or damaged parts as necessary.
- Wipe the machine clean of cutting fluids, dirt and grime.
- Coat it with a light film of oil.

Every 20 Hours of Operation

- Check the adjustment of the main bearing pre-load. It should only take light force to rotate the drive shaft with the ratchet wrench.
- Check the adjustment of the Tool Module slides and gib rails.
- Lubricate the male and female tool slides and the feed screw.

Every 40 Hours of Operation

- Thoroughly clean and lubricate main gear, drive gear, male and female tool slides, feed screws and Tripper Block Assembly.

Remove the Tripper Pin

1. Loosen the Half Dog Set Screw (P/N 33-0954).
2. Loosen the Ball Plunger (P/N 30-0125).
3. Remove the Tripper Shaft Assembly (P/N 14-0097) from the Tripper Block Assembly (P/N 47-1521).
4. Remove the Cap Screw (P/N 33-2649) and the Knob (P/N 42-0217) from the Tripper Shaft (P/N 20-0803).
5. Insert the Tripper Shaft into the Pin Removal Tool (optional accessory P/N 08-0804).
6. Thread the Pin Removal Screw into the block, tighten with a 5/16" hex wrench (P/N 36-0011) until the pin is removed.

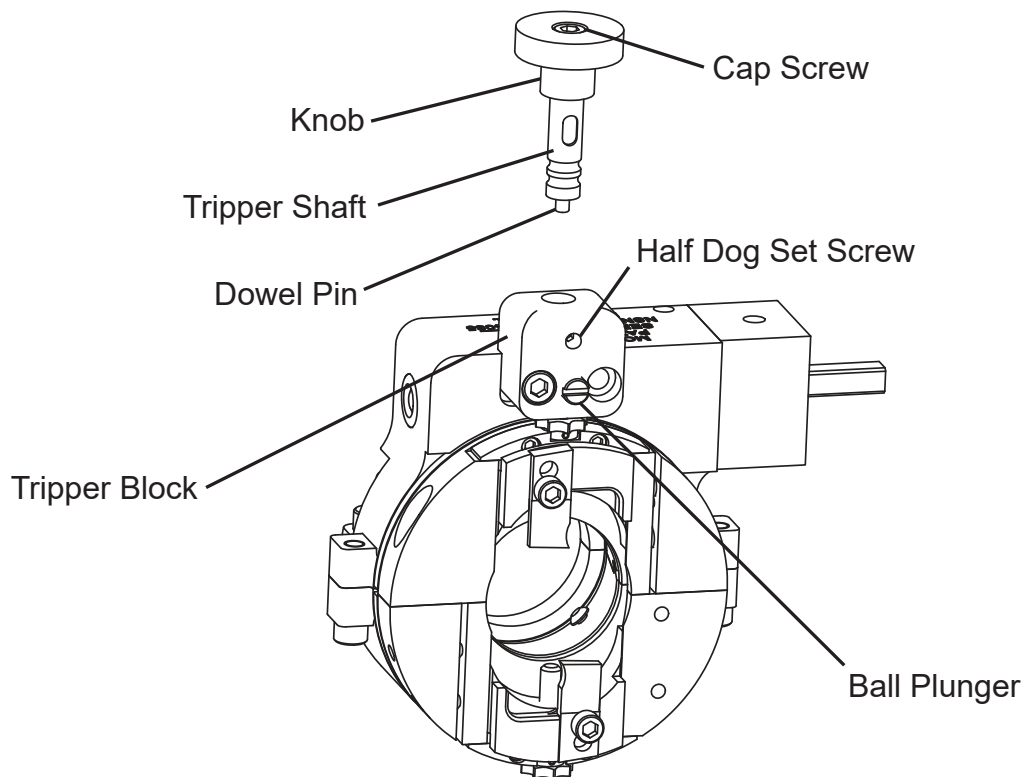

Figure 3: Remove the Tripper Pin

Install a New Tripper

1. Unscrew the Pin Removal Screw.
2. Remove the Tripper Shaft (P/N 20-0803) from tool.
3. Start the Dowel Pin (P/N 32-0220) in Tripper Shaft, insert tapered end.
4. Insert the Tripper Shaft and Dowel Pin into tool.
5. Thread the Pin Installing Screw into tool. Tighten the screw until it stops. This sets the pin to the proper depth.
6. Remove the Pin Installing Screw.
7. Remove the Tripper Shaft and Pin.
8. Reassemble the tool with Pin Removal and Installing Screws.

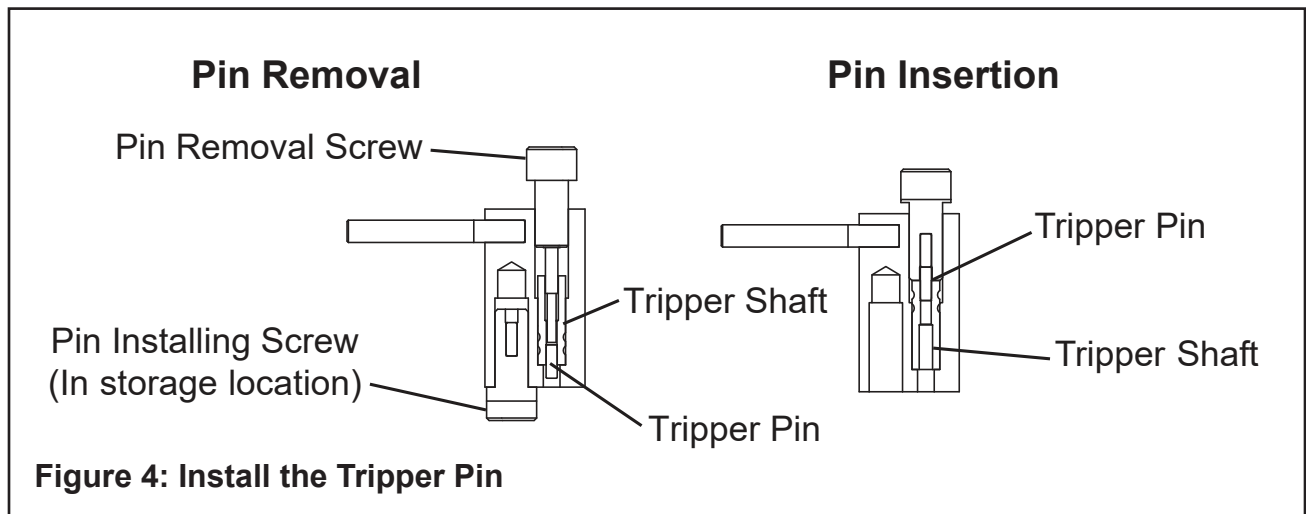

Figure 4: Install the Tripper Pin

Reassemble the Tripper Shaft Assembly

1. Apply Loctite 242 to Cap Screw (P/N 33-2649).
2. Insert Tripper Shaft Assembly in Tripper Block (P/N 48-1322).
3. Apply 242 Loctite to Half Dog Set Screw (P/N 33-0954). Screw in all the way and back off 1/4 turn.
4. Apply 242 Loctite to Ball Plunger Screw (P/N 30-0125). Screw in all the way and back off 1/2 turn.

Clean and Adjust the Tool

1. Remove the Tool Module slide and unscrew the feed screw.
2. Clean and lubricate the male and female slide surfaces. Clean and lubricate the feed screw.
3. Reinstall the feed screw into the Tool Module slide then reinstall the Tool Module slide.
4. Install the star wheel block screws and tighten.
5. Move the Tool Bit holder to the top of the Tool Module. Install the 3/32" wrench into the top adjustment screw. Turn it in until it touches off. Tighten the top adjustment screw and turn the star wheel counterclockwise using the feed sprocket driver. The tension should be a light-firm pressure.
6. Continue to lower the Tool Bit slide and install the 3/32" wrench into the lower adjustment screw. Turn it until it touches off. Tighten the lower adjustment screw when the Tool Bit Holder is being turned down to its lower position.
7. Turn the star wheel clockwise to retract the Tool Bit Holder to the top position. The feed pressure of the feed screw should have a light-firm pressure resistance and remain the same from the bottom to the top of the Tool Module Block.

Adjust the Main Bearing

1. Loosen all main bearing locking screws one full turn with the 7/64" wrench. The locking screws are labeled A through F (refer to Fig. 5).
2. Back off the main bearing adjustment screws 1/2 turn with the 5/64" wrench. The main bearing adjustment screws are labeled 1 through 12.

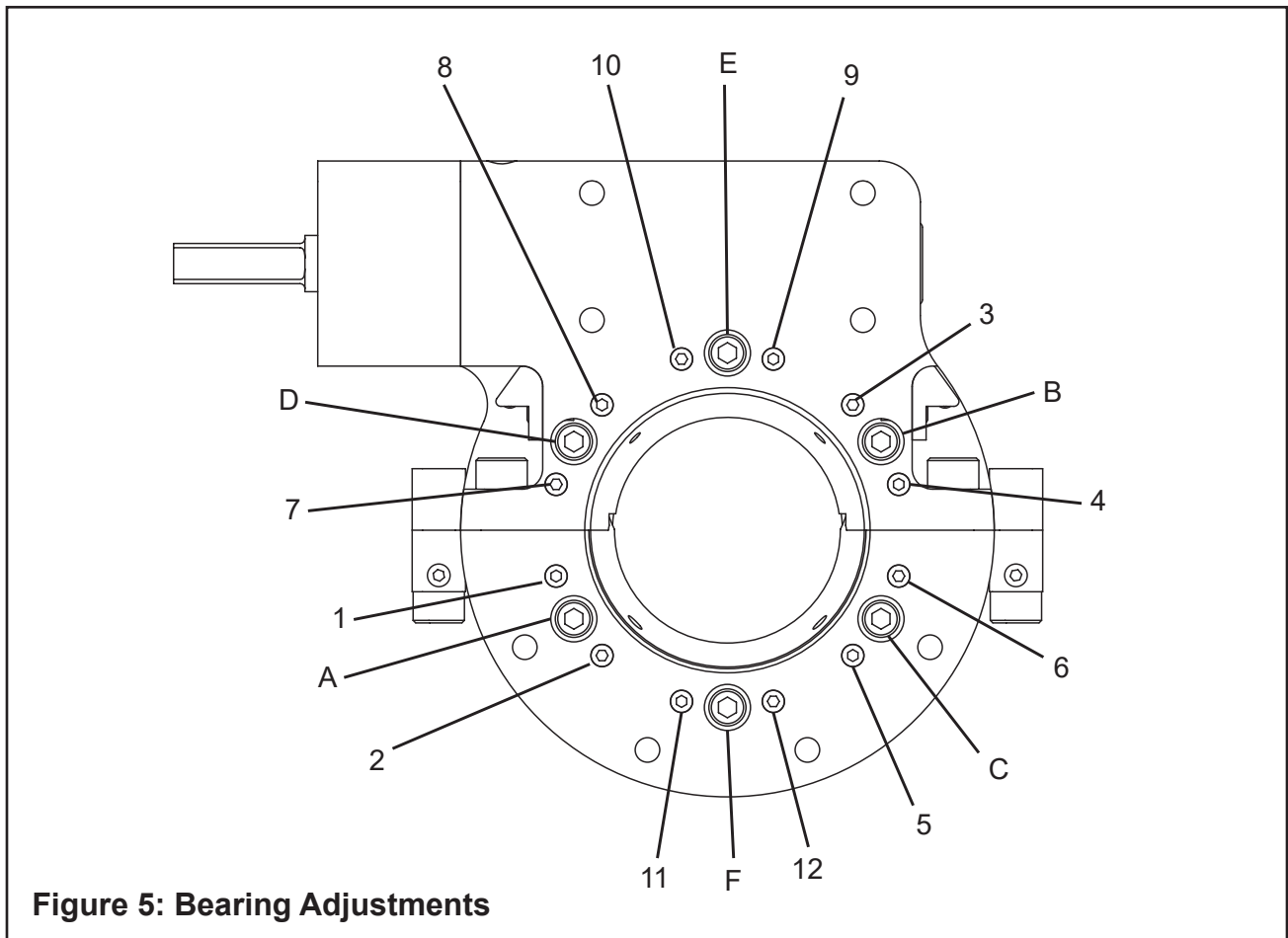

Figure 5: Bearing Adjustments

3. Start at the two main bearing adjustment screws, 1 and 2. Lower adjustment screws 1 and 2 until they touch, then back them off 1/8 turn. Repeat this for screws 3 and 4, 5 and 6, 7 and 8, 9 and 10, and 11 and 12. Turn the 1/4" square drive with the ratchet and make sure there are no tight areas in the main bearing. It should turn without any resistance. If light spots of resistance occur, then repeat the above procedure.
4. Tighten all main bearing locking screws, start with 'A' and going through to 'F'. 5.
5. Re-check the bearing adjustment using the 1/4" square drive. It should be a little looser.

12. STORAGE

General Storage

1. Thoroughly clean the tool by removing all chips and debris.
2. Remove any Tool Bits with the 9/64" hex wrench and store them appropriately in their container.
3. Inspect the tool by checking for loose, worn, or damaged components.
4. Lubricate and spray the tool with a rust preventative prior to storage.

Long Term Storage (30+ Days)

1. For long term storage, lubricate the air motor in addition to performing the General Storage procedures.

Lubricating the Air Motor

1. Remove the air quick disconnect and spray it with a lightweight oil.
2. Squirt oil into the male quick disconnect.
3. Reconnect the air line and turn on the air motor for one (1) or two (2) seconds to coat the internal components.

13. TROUBLESHOOTING

Problem: Tool Bit Chatters

- The tool bit is loose or overextended.
 - The tool bit is damaged.
 - The tool holder is too loose in the slides.
 - The cutting speed is too fast.
 - The clamping pads are loose on the pipe or tube.
 - Cutting fluid is required.
 - The main bearing pre-load is loose.
-

Problem: Excessive Tool Bit Wear

- The pipe or tube material is too hard or abrasive.
 - The cutting speed is too fast.
 - Cutting fluid is required.
 - A dull Tool Bit is causing surface hardening conditions (Stainless pipe or tubing).
 - There is scale or other foreign matter on the pipe or tube, which is dulling the tool bit at the start of the cut.
 - The tool bit is incorrect for the material being cut.
-

Problem: Rough Surface Finish

- The tool bit is dull, chipped, etc.
 - Metal build-up on the cutting edge of the tool bit is creating a false cutting edge.
 - Cutting fluid is required.
 - The cutting speed is incorrect.
-

Problem: Tool Holder Is Not Feeding

- The feed pin is broken or out of position.
 - The feed sprocket shear pin is broken.
 - The feed screw is stripped.
 - The feed nut is stripped.
 - The slide rails are too tight.
-

Problem: Loss Of Air Power

- The air supply pressure is too low.
 - The air filter is plugged.
 - The air line size is insufficient.
 - The air line is too long.
-

Problem: Loss Of Hydraulic Power

- The hydraulic supply pressure is too low.
 - The hydraulic filter is plugged.
 - The hydraulic line size is insufficient.
 - The hydraulic line is too long.
-

Problem: Tool Bit Does Not Reach Work

- Incorrect tool blocks are installed for the size of the pipe or tube being worked on.
 - Incorrect tool bit is installed.
-

Problem: Hydraulic Motor Does Not Start

- The hydraulic power supply is shut off.
- The hydraulic motor is damaged and will not run free.

14. ACCESSORIES

The following accessory is available from Tri Tool Technologies.

AUTO-DISENGAGE TRIPPER (05-0686)

Parts List, Auto-Disengage Tripper (P/N 05-0686)

Item No.	Part No.	Description	Qty
1	05-0686	AUTO-DISENGAGE TRIPPER	1

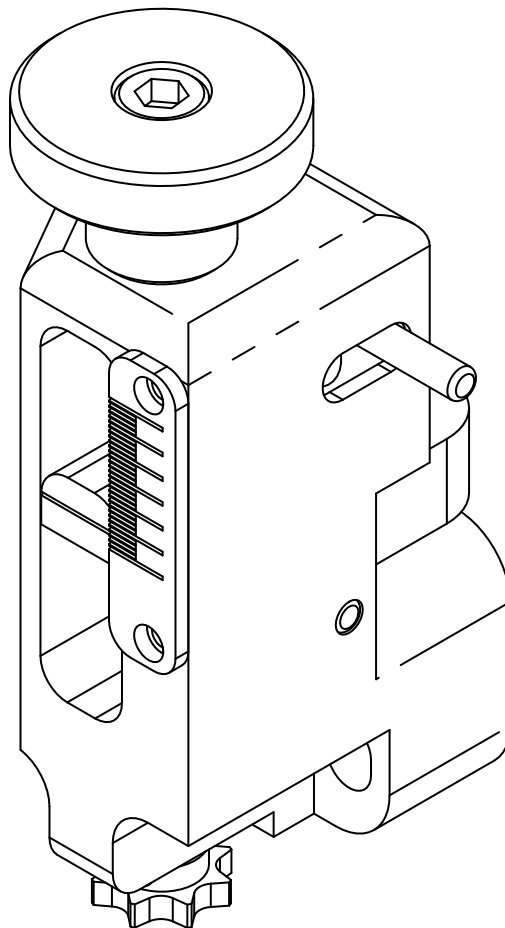

15. ILLUSTRATED PARTS BREAKDOWN

Parts List, 603SBCM Tool Kit (P/N 05-0430)

Item No.	Part No.	Description	Qty
1	01-1818	MODEL 603SBCM CLAMSHELL	1
2	08-0804	BLOCK ASSEMBLY, PIN REMOVAL/INSTALL	1
3	14-0091	SHAFT ASSEMBLY, FLEXIBLE HD	1
4	30-2948	COLLET, SS, 603SBCM, 2.375" (60.31MM)	1
5	30-3132	COLLET, SS, 603SBCM, 2.875" (73.0MM)	1
6	30-3161	COLLET, SS, 603SBCM, 1.660" (42.16MM)	1
7	30-3162	COLLET, SS, 603SBCM, 1.900" (48.26MM)	1
8	57-0269	MOTOR ASSEMBLY, BAYONET	1
9	81-0508	TRAINING DVD, 601SBCM	1
10	86-0158	CONTAINER, COLLET, 100S	2
11	86-0249	CASE, 603SBCM KIT	1
12	86-0256	CONTAINER, COLLET	4
13	99-5941C4	TOOL BIT, SEVER	1
14	99-5942C4	TOOL BIT, DOUBLE BEVEL, 37.5 DEG	1
15	99-5943C4	TOOL BIT, SEVER	1

Parts List, Wrench Kit (05-0397)

Item No.	Part No.	Description	Qty
	05-0397	WRENCH KIT	1
	36-0314	WRENCH ASSEMBLY, SPROCKET	1
	36-0344	WRENCH ASSEMBLY TORQUE BAR	1
	36-0003	WRENCH, L, 3/32" HEX	1
	36-0006	WRENCH, L, 9/64" HEX	1
	36-0020	WRENCH, T, 5/32" HEX	1
	36-0091	WRENCH, RATCHET, 1/4" DRIVE	1
	36-0334	WRENCH, SPANNER	1
	36-0261	WRENCH, DRIVE, 1/4"	1
	36-0262	SOCKET, 1/4"	1
	36-0001	WRENCH, L, 1/16" HEX	1

MODEL 603SBCM CLAMSHELL (P/N 01-1818)

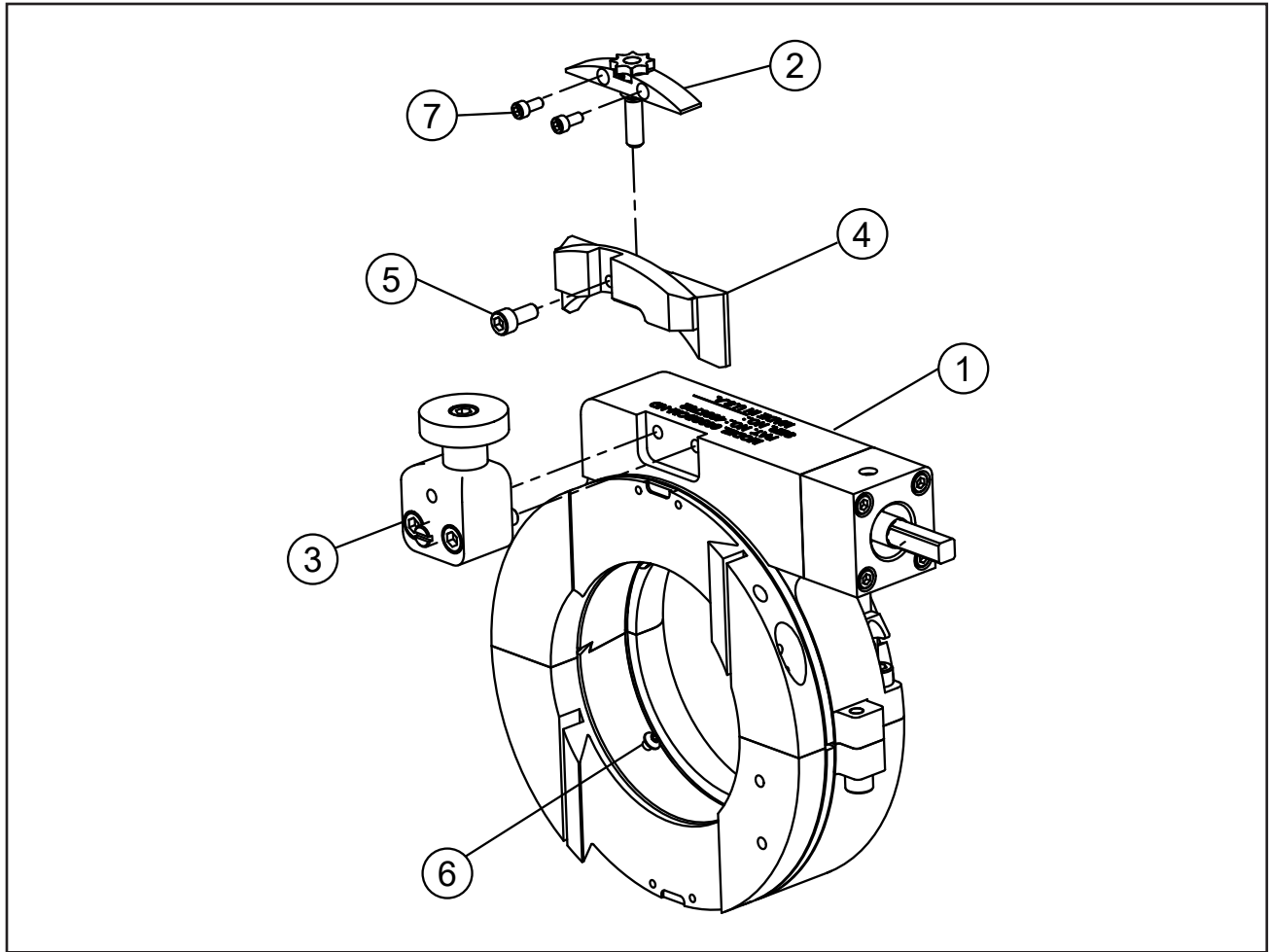

Parts List, Model 603SBCM Clamshell (P/N 01-1818)

Item No.	Part No.	Description	Qty
1	02-2421	603SBCM SUB-ASSEMBLY	1
2	38-0216	SPROCKET ASSEMBLY, FEED	2
3	47-1521	TRIPPER BLOCK ASSEMBLY	1
4	49-0433	HOLDER, TOOL	2
5	33-2647	SCREW, CAP, #8-32 X 3/8" LG, SST	2
	33-2930	SCREW, CAP, #8-32 X 5/8" SS	2
6	33-2531	SCREW, BUTTON, #4-40 X 3/16" LG	4
7	33-2644	SCREW, CAP, #4-40 X 1/4", SS	4
<i>NOT SHOWN</i>			
	05-0397	WRENCH KIT, 603SBCM	1

MODEL 603SBCM SUB-ASSEMBLY (P/N 02-2421)

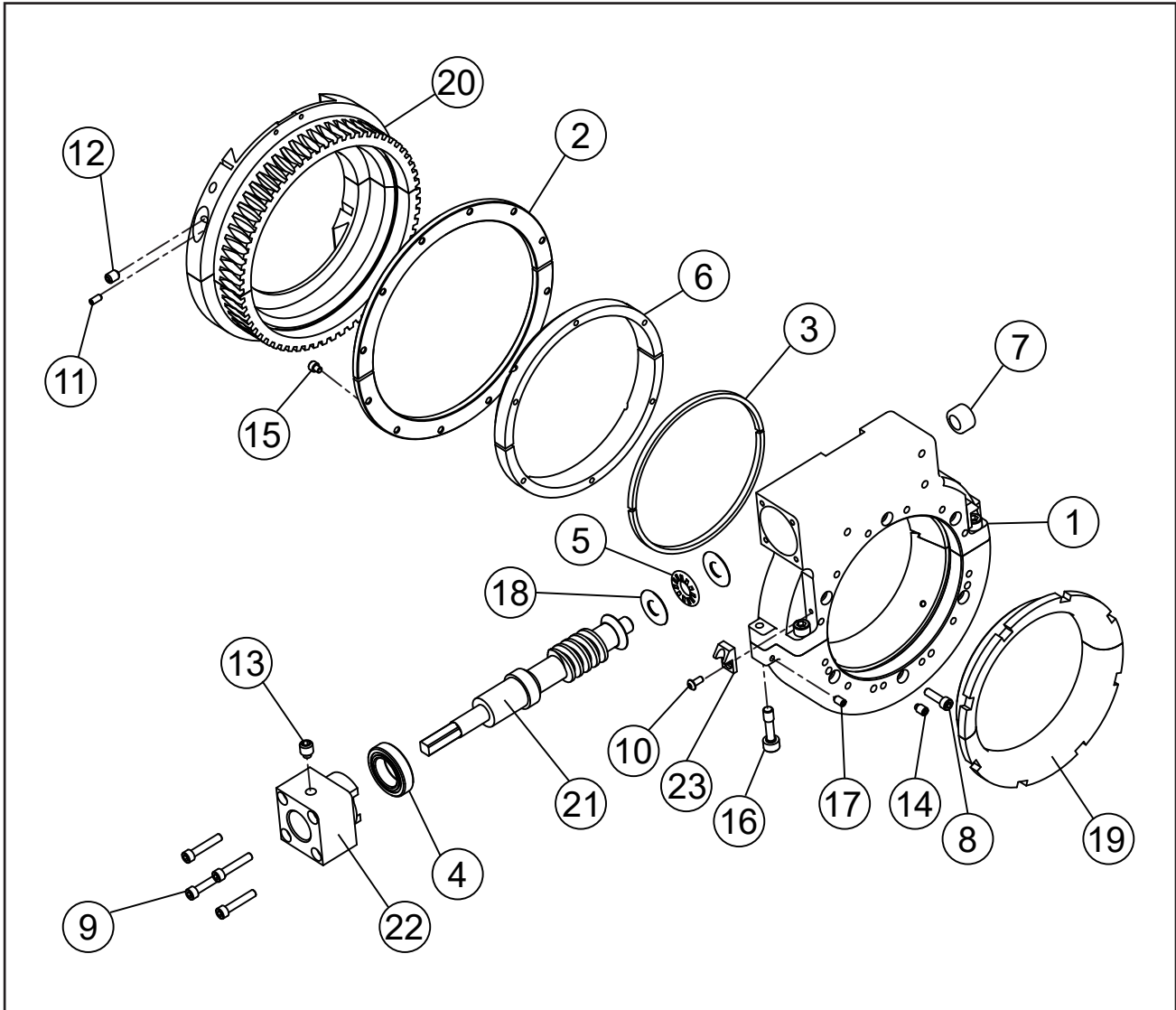

Parts List, Model 603SBCM Sub-Assembly (P/N 02-2421)

Item No.	Part No.	Description	Qty
	19-1086	HOUSING, MAIN, HD	1
2	24-2368	PLATE, THRUST, HD	1
3	28-0367	SEAL, FELT, 3/32" X 1/8" X BULK	10.80
4	29-0064	BEARING, BALL, 5/8" X 1-1/16" X 9/32"	1
5	29-0190	BEARING, THRUST, 5/16" X 3/4" X 5/64"	1
6	29-0475	BEARING, MAIN	1
7	29-0404	BEARING, NEEDLE	1
8	33-2645	SCREW, CAP, #6-32 X 1/2", SST	6
9	33-2646	SCREW, CAP, #6-32 X 1", SST	4
10	33-2489	SCREW, BUTTON, #4-40 X 1/8"	2
11	33-0450	SCREW, SET, #4-40 X 1/4", CUP PT	2
12	33-0488	SCREW, SET, #10-24 X 1/4", CUP PT	4
13	33-0903	SCREW, SET, 1/4-20 X 5/16", HALF DOG	1
14	33-1605	SCREW, SET, #8-32 X 1/4", HALF DOG	12
15	33-2266	SCREW, CAP, #4-40 X 1/8"	12
16	33-2501	SCREW, SPLITLINE, HD	2
17	33-2502	SCREW, SET, #6-32 X .250", H DOG	2
18	34-0202	WASHER, THRUST, 5/16" X 3/4"	2
19	35-0605	NUT, CLAMP	1
20	39-0932	GEAR, MAIN	1
21	39-0916	GEAR, WORM	1
22	43-0577	COVER, WORM	1
23	48-2076	BLOCK, RETAINING	2

HOUSING, MAIN (P/N 19-1086)

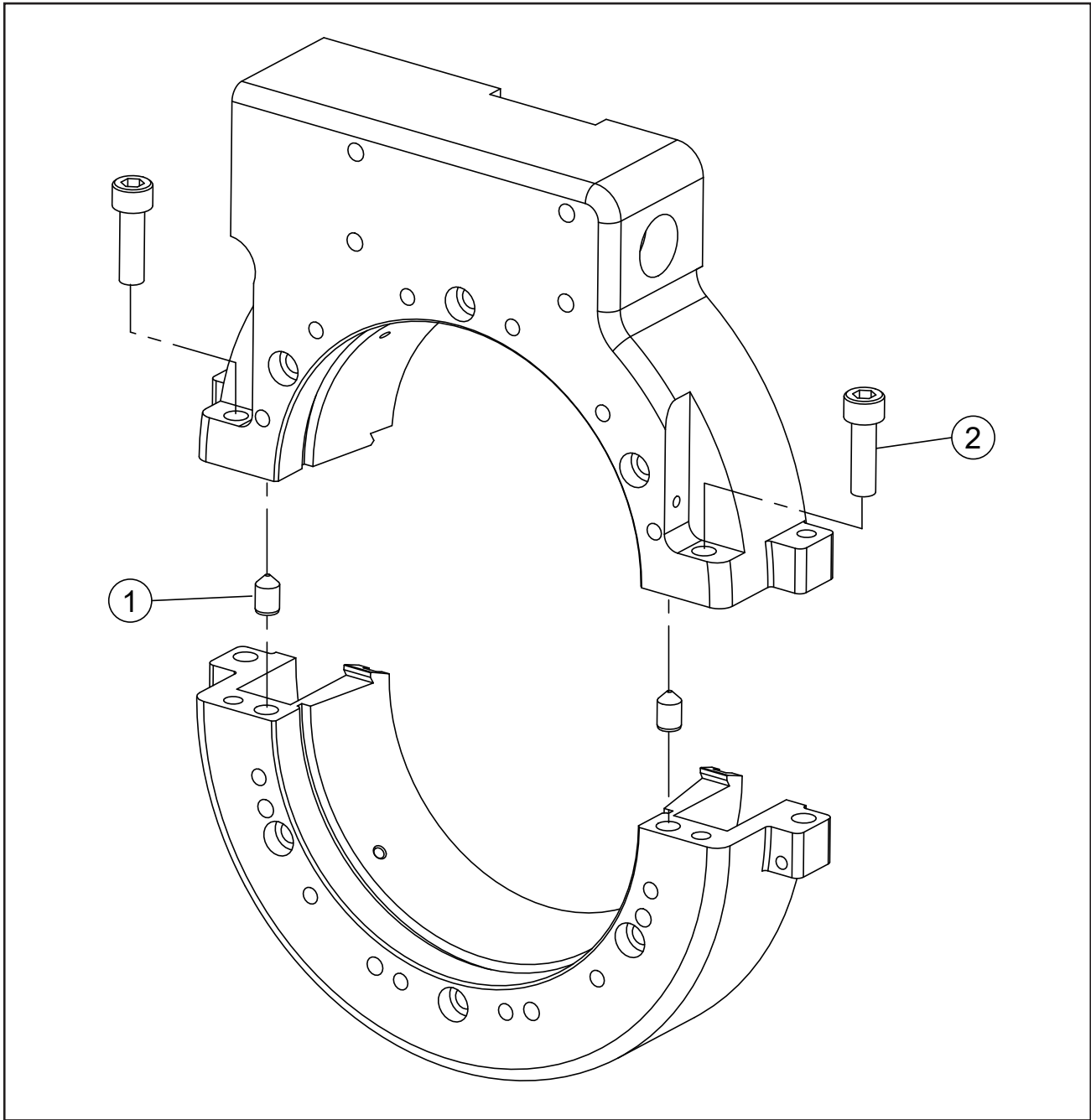

Parts List, Housing, Main (P/N 19-1086)

Item No.	Part No.	Description	Qty
1	32-0598	PIN, ALIGN, 3/16" DIA X 5/16"	2
2	33-2649	SCREW, CAP, #10-24 X 5/8", SST	2

NUT, CLAMP (P/N 35-0605)

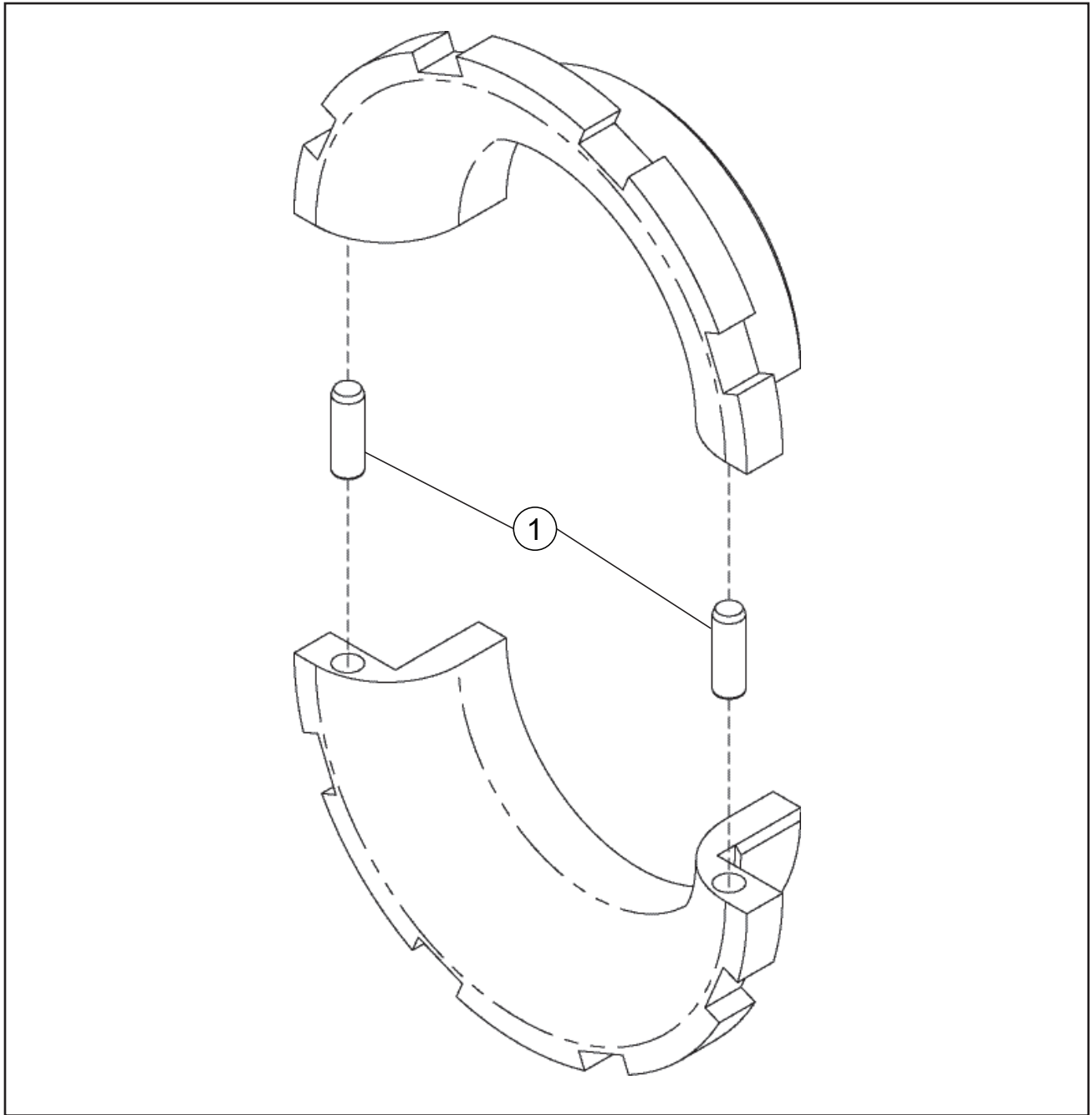

Parts List, Nut, Clamp (P/N 35-0605)

Item No.	Part No.	Description	Qty
1	32-0220	PIN, DOWEL, 1/8" DIA X 3/8"	2

GEAR, MAIN (P/N 39-0932)

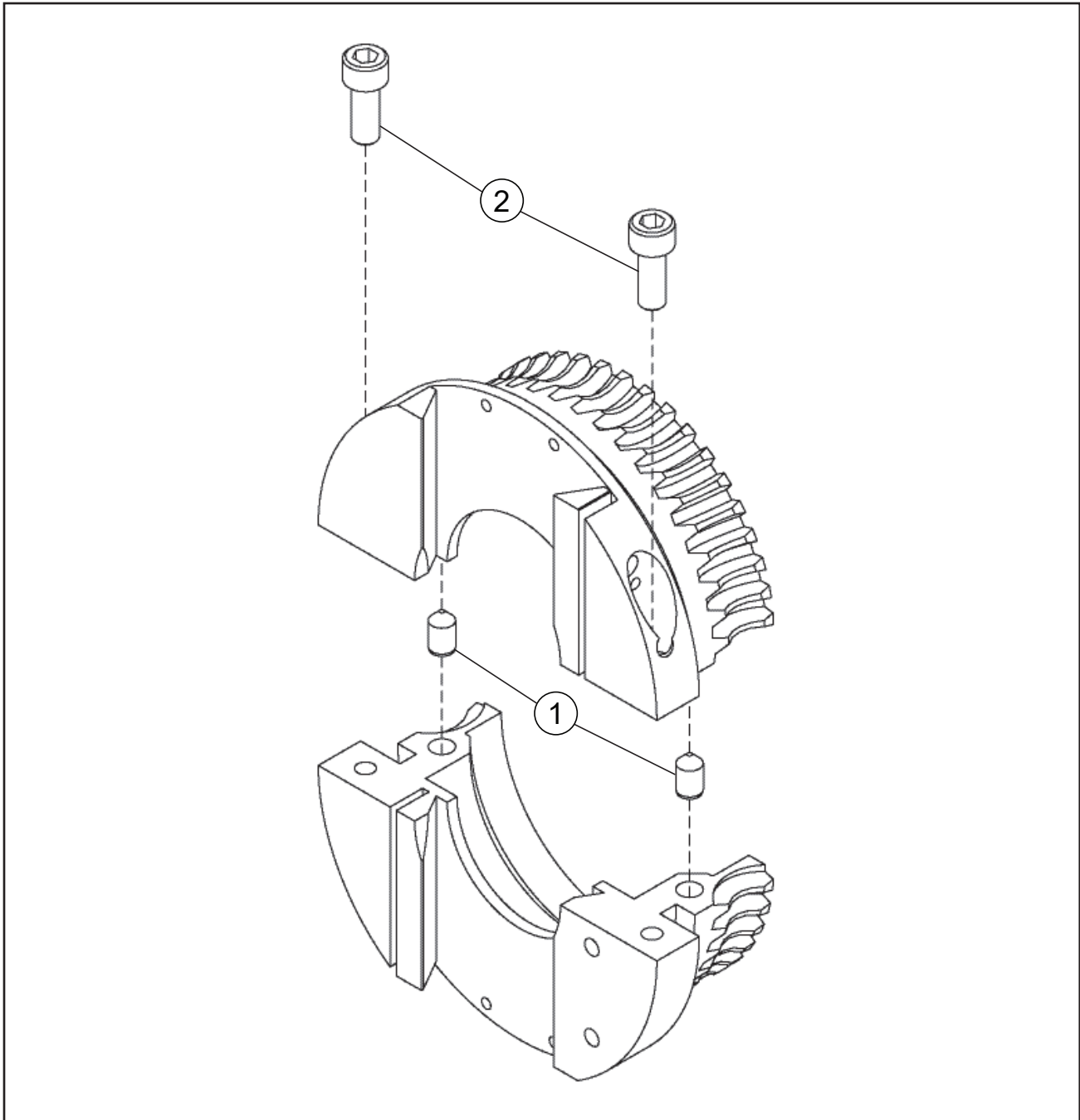

Parts List, Gear, Main (P/N 39-0932)

Item No.	Part No.	Description	Qty
1	32-0598	PIN, ALIGN, 3/16" DIA X 5/16"	2
2	33-2649	SCREW, CAP, #10-24 X 5/8", SST	2

BLOCK ASSEMBLY, TRIPPER PIN REMOVAL/INSTALL (P/N 08-0804)

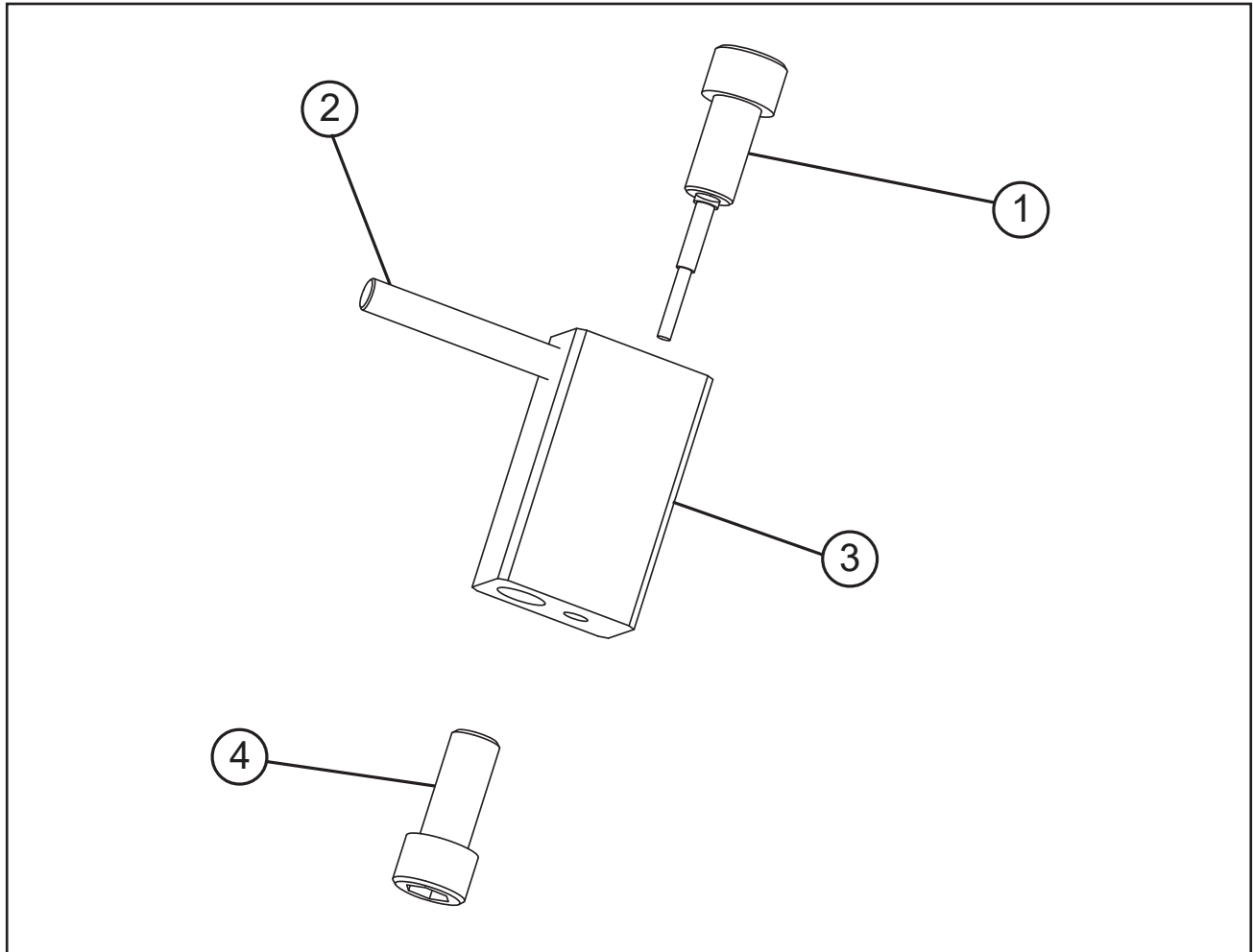

Block Assembly, Tripper Pin Removal/Install (P/N 08-0804)

Item No.	Part No.	Description	Qty
1	33-2503	SCREW, TRIPPER PIN REMOVAL	4
2	32-0210	PIN, DOWEL	1
3	48-1882	BLOCK, TRIPPER PIN REMOVAL	1
4	33-2490	SCREW, PIN INSTALLATION	1
<i>NOT SHOWN</i>			
	36-0011	5/16" ALLEN WRENCH	1

SHAFT ASSEMBLY, FLEXIBLE HD (P/N 14-0091)

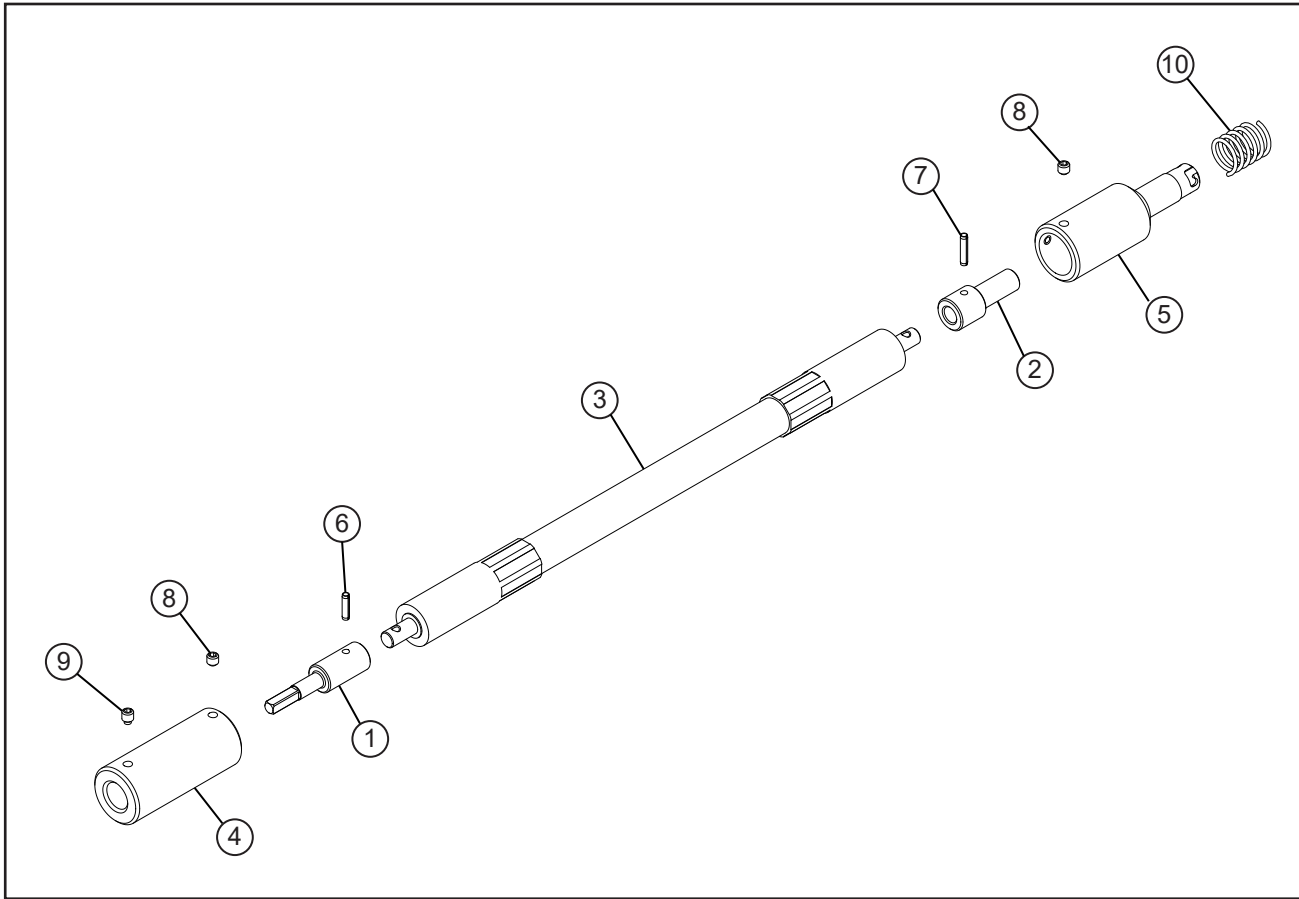

Parts List, Shaft Assembly, Flexible HD (P/N 14-0091)

Item No.	Part No.	Description	Qty
1	20-0844	SHAFT, DRIVE, FLEX	1
2	20-0845	SHAFT, ADAPTER, FLEX	1
3	20-0904	SHAFT, FLEXIBLE, 18" HEAVY DUTY	1
4	27-0726	ADAPTER, SQUARE, FLEX SHAFT	1
5	27-0727	ADAPTER, BAYONET, FLEX SHAFT	1
6	32-0034	PIN, ROLL, 5/32" DIA X 5/8"	1
7	32-0035	PIN, ROLL, 5/32" DIA X 3/4"	1
8	33-0498	SCREW, SET, 1/4-20 X 3/16", CUP PT	4
9	33-0903	SCREW, SET, 1/4-20 X 5/16", HALF DOG	1
10	40-0143	SPRING, MUSIC WIRE, LC-085K-3M	1

BLOCK ASSEMBLY, TRIPPER (P/N 47-1521)

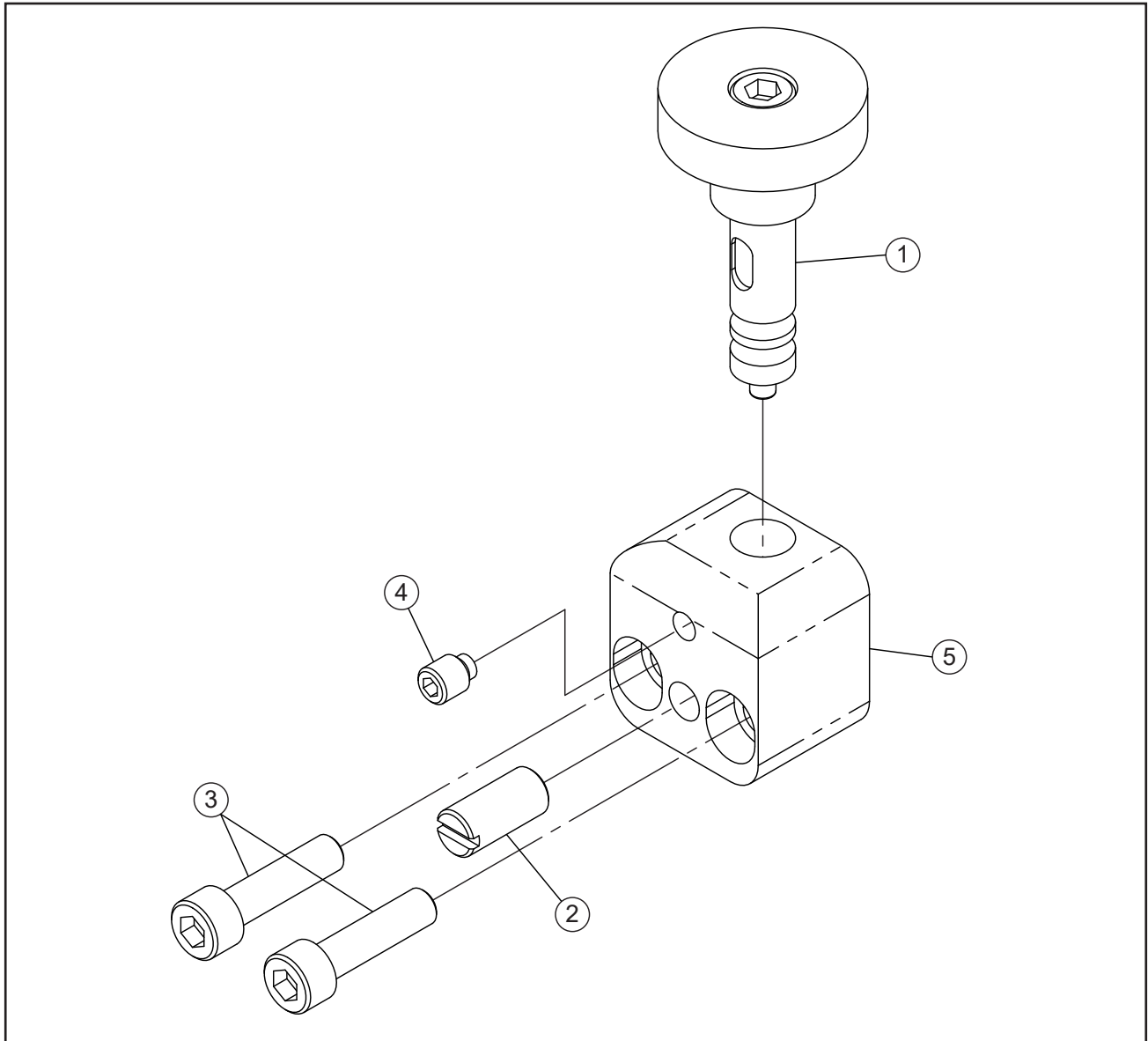

Parts List, Block Assembly, Tripper (P/N 47-1521)

Item No.	Part No.	Description	Qty
1	14-0097	SHAFT ASSEMBLY, TRIPPER	1
2	30-0125	PLUNGER, BALL, 1/4-20 X 17/32"	1
3	33-2650	SCREW, CAP, #10-24 X 3/4", SST	2
4	33-0954	SCREW, SET, #10-24 X 1/4", HALF DOG	1
5	48-1322	BLOCK, TRIPPER	1

SHAFT ASSEMBLY, TRIPPER (P/N 14-0097)

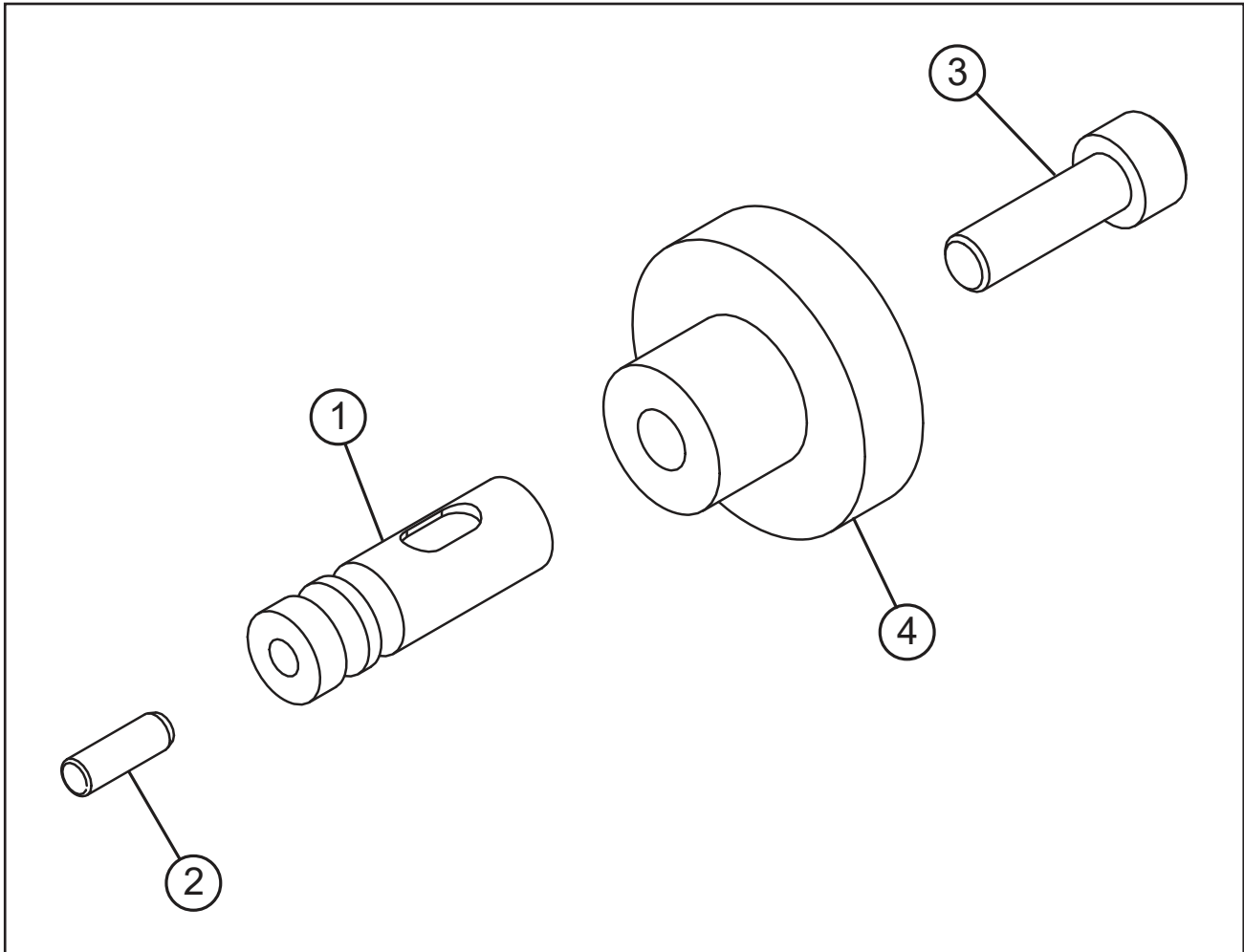

Parts List, Shaft Assembly, Tripper (P/N 14-0097)

Item No.	Part No.	Description	Qty
1	20-0803	SHAFT, TRIPPER	1
2	32-0220	PIN, DOWEL, 1/8" DIA X 3/8"	1
3	33-2649	SCREW, CAP, #10-24 X 5/8", SST	1
4	42-0217	KNOB	1

MOTOR ASSEMBLY, BAYONET (P/N 57-0269)

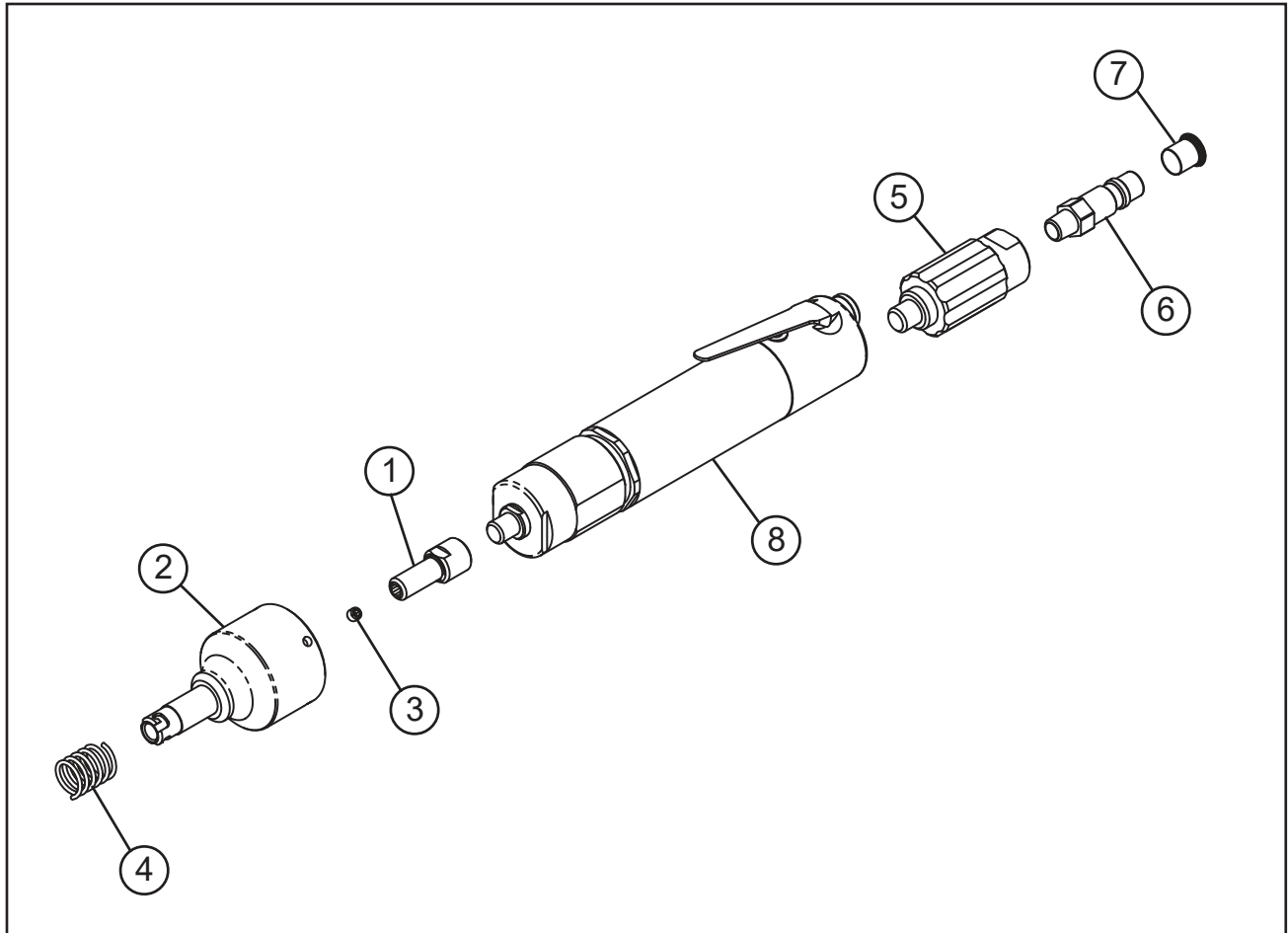

Parts List, Motor Assembly, Bayonet (P/N 57-0269)

Item No.	Part No.	Description	Qty
1	20-0806	SHAFT, DRIVE	1
2	27-0703	ADAPTER, BAYONET	1
3	33-0498	SCREW, SET, 1/4-20 X 3/16", CUP PT	4
4	40-0143	SPRING, MUSIC WIRE, LC-085K-3	1
5	53-0045	VALVE, FLOW CONTROL, 1/4" NPT	1
6	54-0149	COUPLING, MAIL, QD, HOSE TO PIPE	1
7	54-0201	CAP, YELLOW	1
8	57-0257	MOTOR, AIR	1

MOTOR ASSEMBLY, 220V, SBCM (P/N 58-0463)

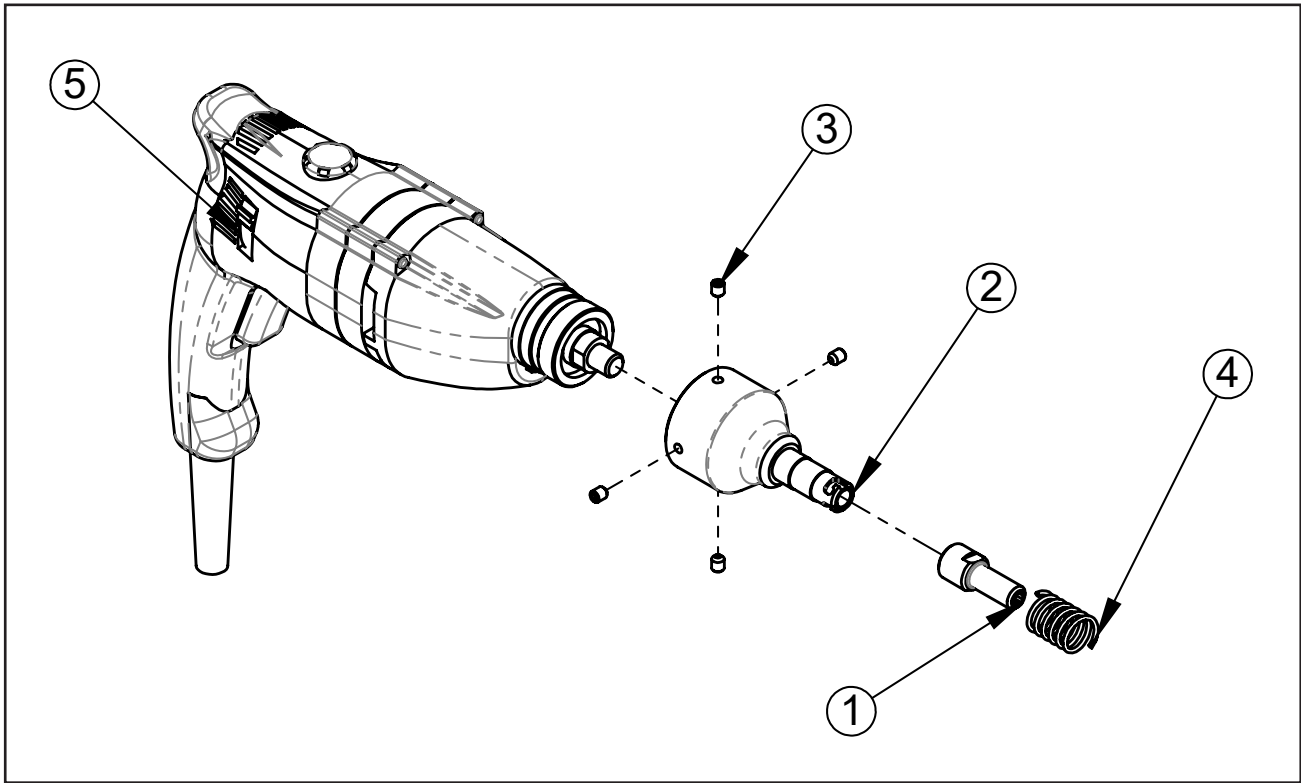

Parts List, Motor Assembly, 220V, SBCM (P/N 58-0463)

Item No.	Part No.	Description	Qty
1	20-1606	SHAFT, DRIVE	1
2	27-1461	ADAPTER, BAYONET	1
3	33-0500	SCREW, SET, 1/4-20 X 5/16" CUP PT	4
4	40-0143	SPRING, MUSIC WIRE, LC 085K 03M	1
5	58-0321	MOTOR, C.W. ELEC, METABO, 230V	1

MOTOR ASSEMBLY, 110V, SBCM (P/N 58-0467)

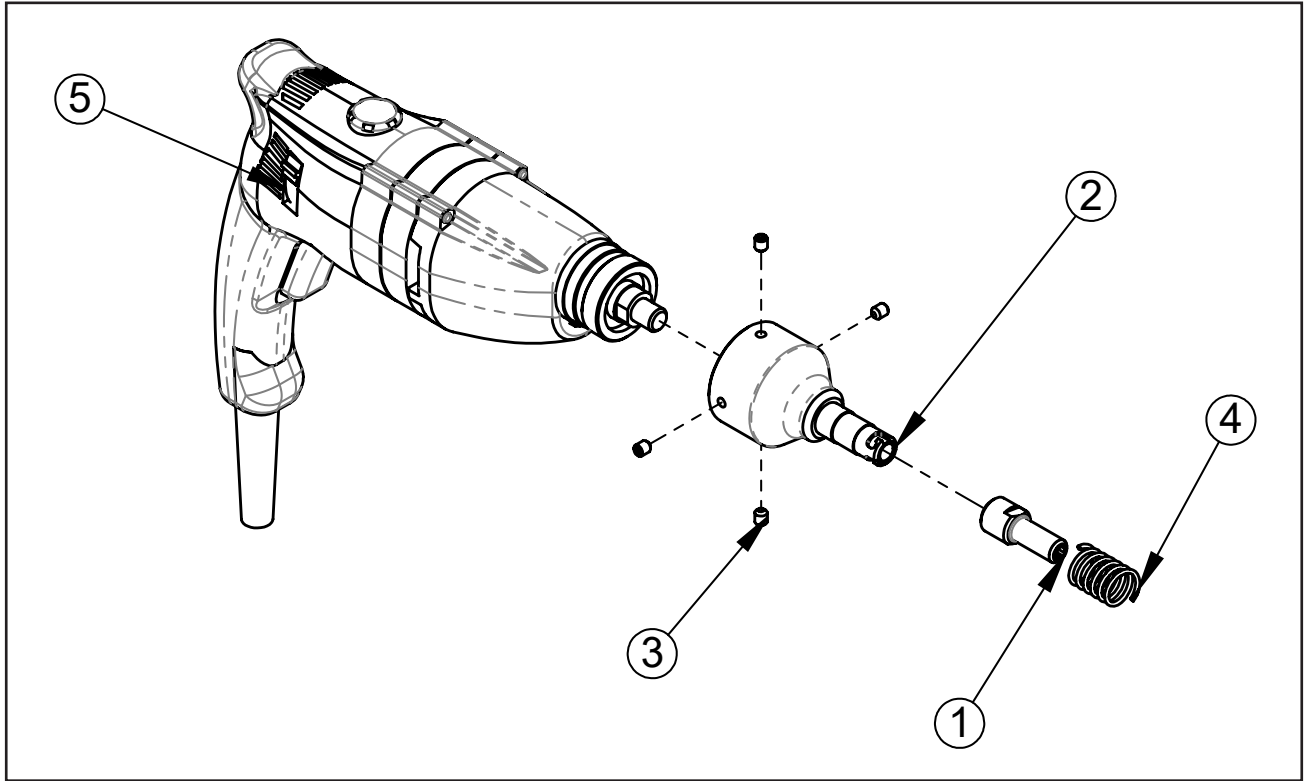

Parts List, Motor Assembly, 110V, SBCM (P/N 58-0467)

Item No.	Part No.	Description	Qty
1	20-1606	SHAFT, DRIVE	1
2	27-1461	ADAPTER, BAYONET	1
3	33-0500	SCREW, SET, 1/4-20 X 5/16" CUP PT	4
4	40-0143	SPRING, MUSIC WIRE, LC 085K 03M	1
5	58-0466	MOTOR, C.W. ELEC, METABO, 110V	1

WRENCH ASSEMBLY, SPROCKET (P/N 36-0314)

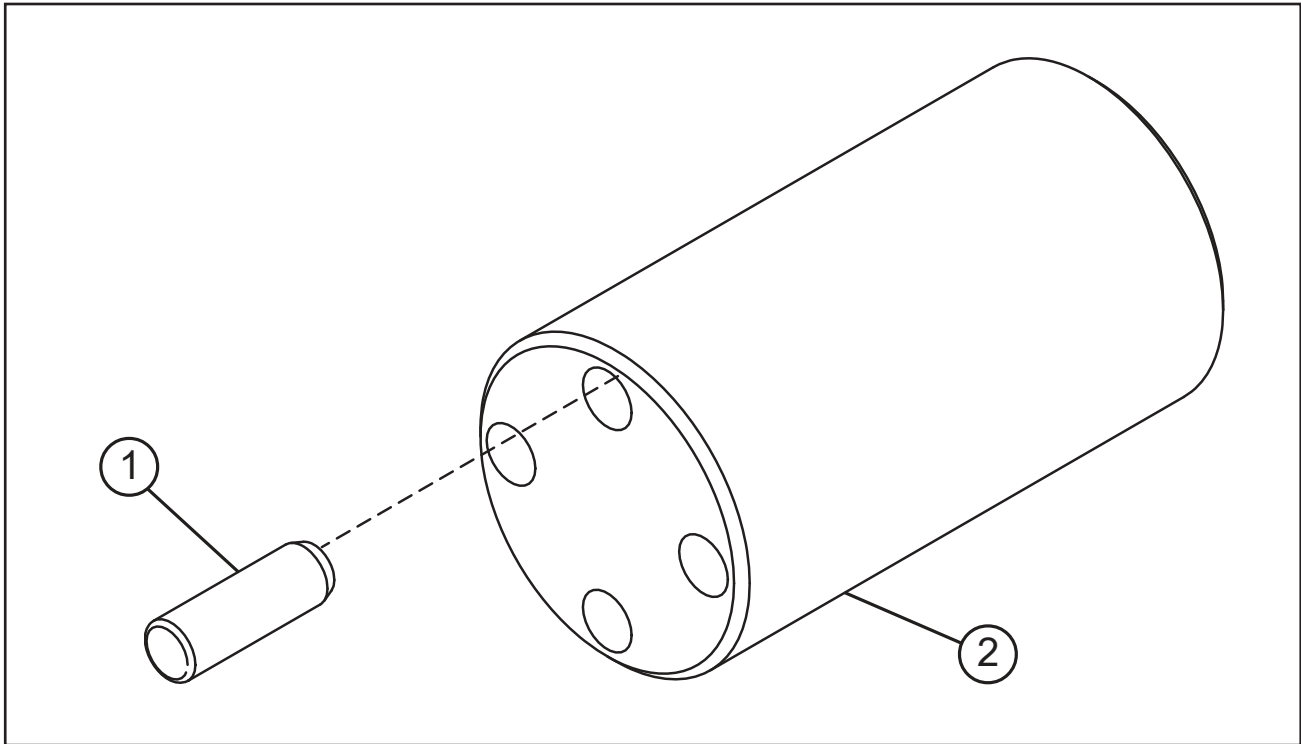

Parts List, Wrench Assembly, Sprocket (P/N 36-0314)

Item No.	Part No.	Description	Qty
1	32-0220	PIN, DOWEL, 1/8" DIA X 3/8"	4
2	36-0315	WRENCH, SPROCKET	1

WRENCH ASSEMBLY, TORQUE BAR (P/N 36-0344)

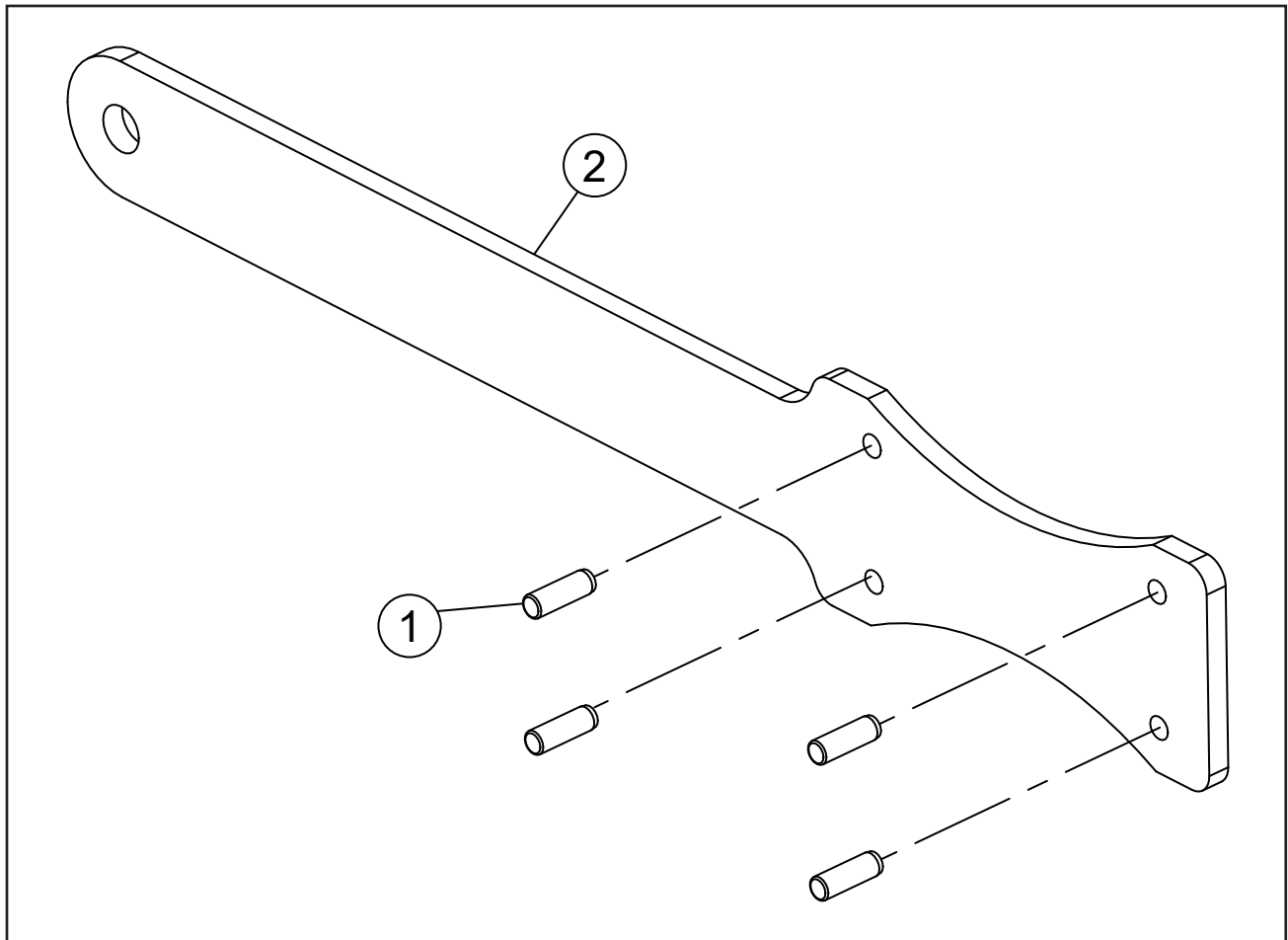

Parts List, Wrench Assembly, Torque Bar (P/N 36-0344)

Item No.	Part No.	Description	Qty
1	32-0220	PIN, DOWEL, 1/8" DIA X 3/8"	4
2	63-0215	BAR, TORQUE	1



WARNING



Read the manual and be familiar with all safety precautions before operating equipment. The following are general warnings for industrial equipment with moving parts. Refer to the manual for specific warnings applicable to your equipment.



EYE HAZARD - Always wear appropriate eye protection while operating the equipment.



PINCH HAZARD - Keep your hands and clothing away from moving parts.



CRUSH HAZARD - The machinery, pipe, or work piece can shift, separate, lurch, or fall.



CHIP HAZARD - Metal chips may be hot and sharp. Be careful when you clear the tooling path or clean up chips.



TIE DOWN HAZARD - Deliberate overriding of safety triggers can result in serious injury. Never lock or tie down any safety triggers.



SHOCK HAZARD - Ensure that the equipment is properly installed and grounded. Ensure that the equipment is not damaged and that the power cord is intact.

OTHER HAZARDS

- Tool bits are sharp and can cause serious injury.
- Do not defeat or modify safety features.
- Disconnect power sources before servicing or moving the equipment.
- Remove all loose articles of clothing and jewelry before operating the equipment.

Be Safety Conscious!



3041 Sunrise Blvd.
Rancho Cordova, CA 95742
+1(916) 288-6100 • +1(800) 345-5015
www.tritool.com