

OPERATION MANUAL

92-0139 Rev. 241126
Model 602TSB Low Profile Clamshell



ABOUT TRI TOOL TECHNOLOGIES



At Tri Tool Technologies, we are committed to your success through relentless innovation and powerful partnership. We insist on developing tools and equipment that exceed your expectations of performance, precision, safety, and durability. As a full-service engineering firm, we are here to support you every step of the way.

For more information on engineered solutions, products, and trainings, visit tritool.com or contact our engineers at +1 (916) 288-6100.

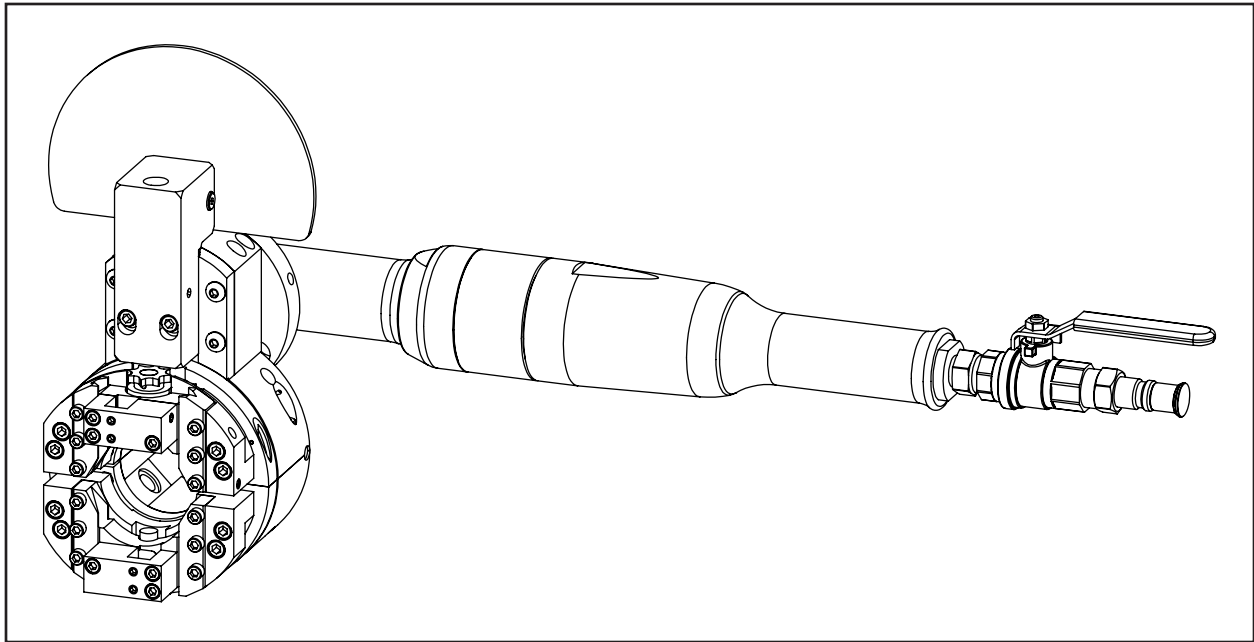

TABLE OF CONTENTS

TRI TOOL TECHNOLOGIES WARRANTY	2
TOOL BIT RESHARPENING POLICY	3
ABOUT THE MANUAL	4
SAFETY PRECAUTIONS	6
GENERAL DESCRIPTION	8
SPECIFICATIONS	9
MAINTENANCE	11
OPERATION	20
CUTTING SPEEDS AND FEEDS	28
CLAMPING PAD SETS	29
TOOL BITS	30
TOOL BLOCKS	36
TROUBLESHOOTING	37
ACCESSORIES	40
ILLUSTRATED PARTS BREAKDOWN	41
RECOMMENDED SPARE PARTS	51

Tri Tool Technologies Warranty

LIMITED WARRANTY: All products manufactured by Seller are warranted to be free from defects in materials and workmanship under normal use. The period of this warranty shall be three years from the date of shipment for all products, except for welding and Non-Standard Products which shall be one year from the date of shipment. The Buyer shall bear all shipping, packing and insurance costs and all other costs to and from a designated repair service center. All return goods must be authorized in advance and communicated upon issuance of a Return Material Authorization (RMA) by Seller. The product will be returned to the Seller accompanied by a RMA number and associated paperwork, freight prepaid and billed to the Buyer. This warranty is not transferable and will not apply to tool bits or other consumables, or to any Goods to have been (i) mishandled, misused, abused or damaged by Buyer or any third party; (ii) altered without the express permission in writing by Seller, (iii) repaired by a party other than Seller without Seller's prior written approval; or (iv) improperly stored, installed, operated, or maintained in a manner inconsistent with Seller's instructions. This warranty does not apply to defects attributed to (i) normal wear and tear or (ii) failure to comply with Seller's safety warnings.

No warranty for any parts or other supplies provided to seller by buyer, whether or not they are incorporated into goods. Goods supplied by seller which are designed or manufactured by a third party are subject strictly to the third party's warranty for those goods. Seller makes no warranty and disclaims all statutory or implied warranties for these goods, including the implied warranties of merchantability, freedom from patent infringement and fitness for a particular purpose.

Neither this warranty nor any other warranty, expressed or implied, including implied warranties of mechanical ability, fitness for a particular use, or merchantability, shall extend beyond the warranty period. No responsibility is assumed for any incidental or consequential damages. Some states do not allow limitations on how long an implied warranty lasts and some states do not allow the exclusion or limitations incidental or consequential damages, so the above limitation of exclusion does not apply to all Buyers. This warranty gives the Buyer specific legal rights. Other rights vary from state to state.

Warranty Claims and Remedies

Buyer must promptly notify Seller in writing during the applicable warranty period, of any defective Goods covered by Seller's warranties under the Limited Warranty section herein, and no later than fifteen (15) calendar days after discovery of the defect. Seller has no obligation to honor any warranty claim made after the expiration of the warranty period. However, despite the expiration of the warranty period, Seller, at its reasonable discretion, may accept warranty claims submitted up to fifteen (15) calendar days after the expiration of the warranty period provided that Buyer provides Seller with credible and persuasive documentary evidence that the defect was discovered during the warranty period. No warranty claims submitted after this fifteen (15) day calendar period will be considered by Seller.

Buyer's notice of a defective Goods must identify the specific Goods affected, and the nature of the defect. It is required when returning the defective Goods, that it is suitably packed, fully insured, and transportation and insurance prepaid in accordance with instructions issued by Seller. Seller, at its sole option, will either repair or replace any Goods authorized for return to Seller. Such repair, replacement, or credit shall be Buyer's sole remedy for defective Goods. Buyer must promptly provide Seller with all information requested regarding the identified defect.

If the defect claimed by Buyer cannot be reproduced or otherwise verified by Seller, the Goods will be returned to Buyer unmodified at Buyer's expense.

The warranty period for repaired or replaced Goods shall be (i) ninety (90) days or (ii) the unexpired portion of the original warranty period. Under no circumstances is Seller liable for recall, retrieval, removal, dismantling, re-installation, redeployment, or re-commissioning of any defective Goods or any costs associated therewith.

Tool Bit Resharpener Policy

Buyer is required to check all tool bits prior to returning and ensure they are packaged well for shipment. The price structure is available from the Seller's sales coordinator. Seller cannot resharpen badly gouged, chipped, or broken tool bits. Seller will return tool bits that are not suitable for resharpening with the tool bits that were resharpened upon Buyer's request. Buyer is responsible for all shipping charges to and from Seller.



1. ABOUT THE MANUAL

Copyright

©Copyright Tri Tool Technologies. Proprietary property of Tri Tool Technologies. No reproduction, use, or duplication of the information shown hereon is permitted without the express written consent of Tri Tool Technologies.

Disclaimer

The instructions and descriptions in this manual were accurate when the manual was written. However, the information in the manual is subject to change without notice. Check for updated information before you start any job. The Tri Tool Technologies web site has the most current information.

Do not operate or work on this equipment unless you have read and understood the instructions in this Manual. Failure to follow the instructions or follow the safety instructions could result in serious injury or death. This manual describes conditions and hazards that are common and anticipated during equipment operation. No manual can address all conditions which may occur.

Safety Symbols

The manual may contain one or more safety symbols. These symbols and the associated text warn you of potentially hazardous conditions. Examples of the safety symbols and the associated text follow:



DANGER

DANGER: Indicates a hazardous situation that, if not avoided, will result in serious injury or death.



WARNING

WARNING: Indicates a hazardous situation that, if not avoided, could result in serious injury or death.



CAUTION

CAUTION: Indicates a hazardous situation that, if not avoided, could result in minor or moderate injury, or cause property damage.



SAFETY GLASSES: Indicates a hazardous situation that requires the use of safety glasses.



HOT SURFACE

HOT SURFACE: Indicates a hazardous situation that hot surfaces may be present.



GLOVES

GLOVES: Indicates a hazardous situation that requires gloves.



SHOCK HAZARD

ARC FLASH & SHOCK HAZARD: High voltage. Entry by authorized personnel only. Appropriate PPE and tools required when working on this equipment.



READ MANUAL

READ MANUAL: Read manual before use, refer to manual for Tri Tool Technologies machine being used.



DISCONNECT FROM POWER

DISCONNECT FROM POWER: Disconnect main plug from electrical outlet before performing all maintenance.

2. SAFETY PRECAUTIONS

In General

Use standard safety equipment such as: hard hats, safety shoes, safety harnesses, protective clothes, and other safety devices when appropriate.

Operate this tool only in accordance with specific operating instructions.



WARNING: Do not override the deadman switch on the power unit. Locking down, obstructing, or in any way defeating the deadman switch on the power drive unit may result in serious injury.

Personal Protective Equipment

Use standard safety equipment such as: hard hats, safety shoes, safety harnesses, protective clothes, and other safety devices when appropriate.

Wear safety glasses.

Do not wear loose clothing or jewelry.

Wear nonskid footwear.

Put long hair in a cap or a net to make sure hair does not get tangled in equipment.

Personnel

Only personnel who are trained or are being trained may operate the equipment.

Keep the operation manual available where the equipment is used.

The operator must read the operation manual before using the equipment.

The equipment must be operated in accordance with the manual information.

The operator must follow the safety precautions in this manual and good engineering practices to reduce the risk of injury.

Before using the equipment, the operator must ensure that all safety messages on the equipment are legible.

Work Area

Keep the work area clean.

Keep the area well lit.

Keep items such as electrical cords, cables, rags, rigging straps, away from rotating equipment.

Do not use power-cutting tools in the presence of flammable liquids and gases.

Do not let visitors or untrained personnel near tools that are in use.

Ensure all observers wear eye protection.

Keep proper footing at all times.

Area Equipment

Secure the pipe with clamps, vises, chains or straps.

Ensure that both sides of the pipe at the cut site are fully supported so that the pipe will not move after the cut is completed. Long lengths of pipe may be under load and the separation of the pipe can release pressure. This pressure can cause both sides of the pipe to move.

Tool Care

Keep tools in good operating condition. Sharp tool bits perform better and are safer than dull tool bits.

Do not use damaged tools. Always check your tools for damage especially if a tool has malfunctioned, been dropped or hit, check it for damage.

Before you start operating the equipment, do no-load tests and feed function checks.

Tool Use

Use the right tool and tool bit for the job. Contact Tri Tool Technologies to help with your application.

Keep the tool bits fully engaged in the tool bit holders. Loose bits are sharp and can cause cuts or punctures.

Disconnect power supply during setup and maintenance. Use all 'Stop' or Shut off' features available when changing or adjusting tool bits, maintaining the tool, or when the tool is not in use.

Remove adjusting keys and wrenches before applying power to the equipment. Check the tool before turning it on to make sure that all keys and wrenches have been removed.

Do not force tools. Tools and tool bits function better and safer when used at the recommended speeds.

Do not reach into rotating equipment.

Do not reach into the rotating head stock to remove chips, to make adjustments, or to check the surface finish.

Handle chips with care. Chips have very sharp edges and are hot. Do not try to pull chips apart with bare hands.

Store tools properly. Disconnect tools from the power source, remove the tool bits, and store in a safe place.

3. GENERAL DESCRIPTION

The Model 602TSB Low Profile Clamshell is a split-frame tube lathe designed for severing and beveling inline tube with a minimum range of 1-1/2" through 2" (38.1mm through 50.8mm) OD with minimal radial and axial clearance.

Using Standard Tool Blocks, the Model 602TSB may be configured to perform the following operations:

- Sever inline tube.
- Sever and bevel inline tube.
- Sever and double bevel inline tube.

Design and Operating Features

The easily adjustable precision bearing surfaces pre-load and stabilize the rotating head to provide long life, low maintenance, stability, and precision.

The Clamshell splits into two halves for mounting on closed loop systems.

All parts are secured to the two halves, thus avoiding the loss of parts and at the same time providing maximum ease of handling.

The Clamshell may be equipped with self-centering Clamping Pads for quick, easy mounting or may be equipped with Adjustable Clamping Pads for out-of-round tube conditions.

Dual Tool Blocks with Auto-feed Sprockets and Adjustable Slides provide maximum maintainability, life, and operator safety, with a minimum of operator training.

The Auto-feed Sprockets provide .003" (.08mm) of radial feed per revolution of the Headstock for a controlled depth of cut.

The drive gears and bearing surfaces are covered for operator safety and are sealed to provide protection from dust and chips.

The operator's controls are located away from the rotating Headstock for the operator's safety.

A modular design concept provides quick, easy maintenance and maximum versatility in the drive and tooling options.

A detachable right-angle Air Motor provides maximum handling ease and low axial clearance.

4. SPECIFICATIONS

Model 602TSB with Standard Air Motor

Weight	13 lbs. (5.6 kg)
Power Requirements	75 cfm at 90 psi (35 lt./sec at 6.3 kg/cm ²) with the standard Air Motor

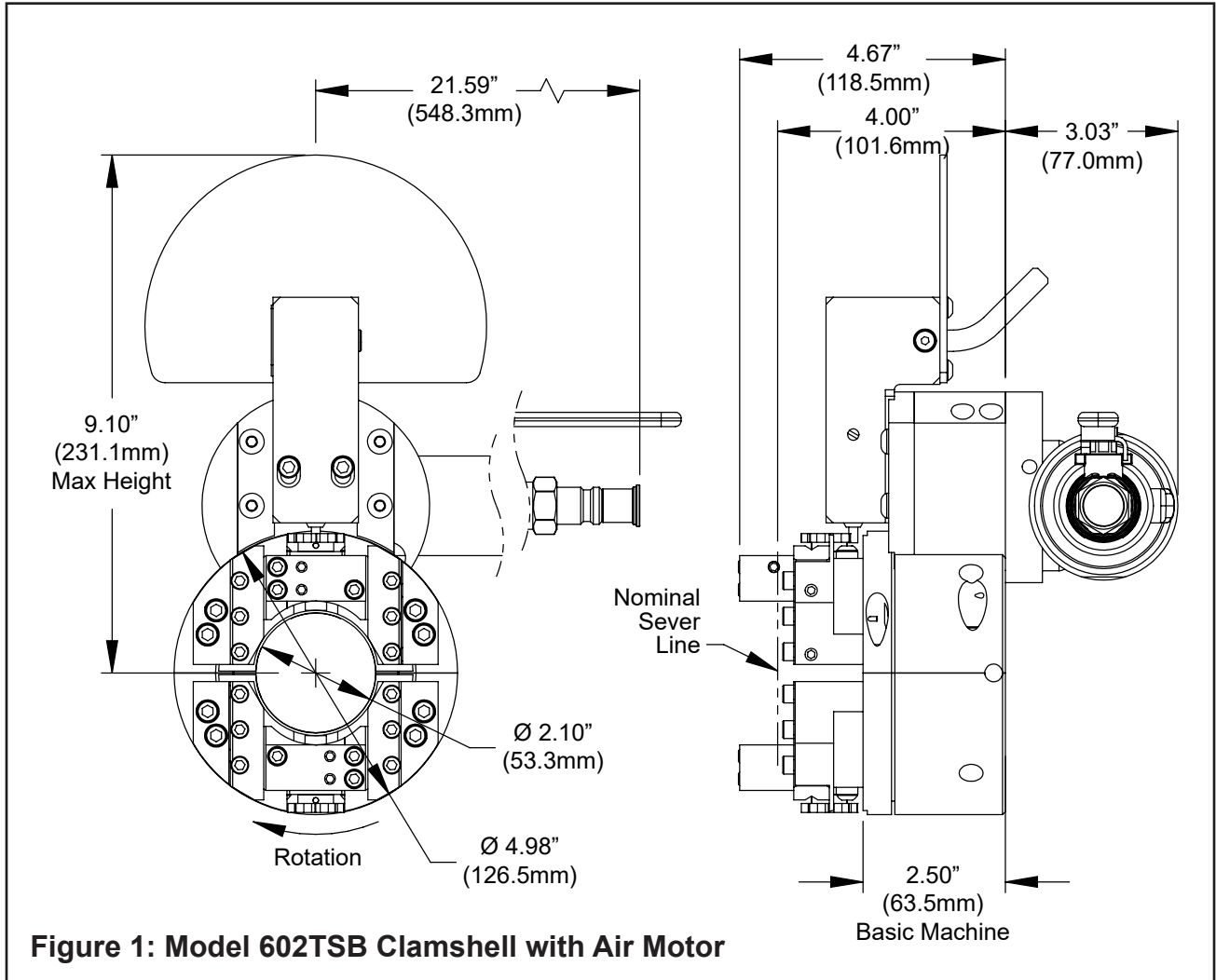

Cutting Capacities on 1-1/2" through 2" OD Tube

Severing with standard procedures	.40" (10.2mm) wall
Severing with special procedures	.80" (20.3mm) wall
Severing and single beveling	.40" (10.2mm) wall
Severing and double beveling	.40" (10.2mm) wall

NOTE: Capacity exceeds the maximum wall thickness for small tube sizes.

Clearances

Rotating parts diameter	4.98" (126.5 mm)
Main Frame diameter	4.98" (126.5 mm)

Axial Clearance Required Relative to Center Line of the Cut

Mounting side	4.00" (101.6 mm)
Side opposite the frame	.68" (17.3 mm)

Radial Clearance Over the Tube

Tube Size		Clearance Standard Tool Blocks	
2.00"	50.8mm	1.49"	37.8mm
1.75"	44.5mm	1.62"	41.1mm
1.50"	38.1mm	1.74"	44.2mm

5. MAINTENANCE

All components should be cleaned and coated with a light film of oil prior to use. Use a clean, non-detergent oil, preferably SAE 10 (90 SSU) or lighter.

Air supply for the Model 602TSB Clamshell with an Air Motor requires an adequate Filter/Regulator/Lubricator (FRL) to be used.

NOTE: The Motor warranty is void if damage occurs from contaminated air or lack of lubrication.

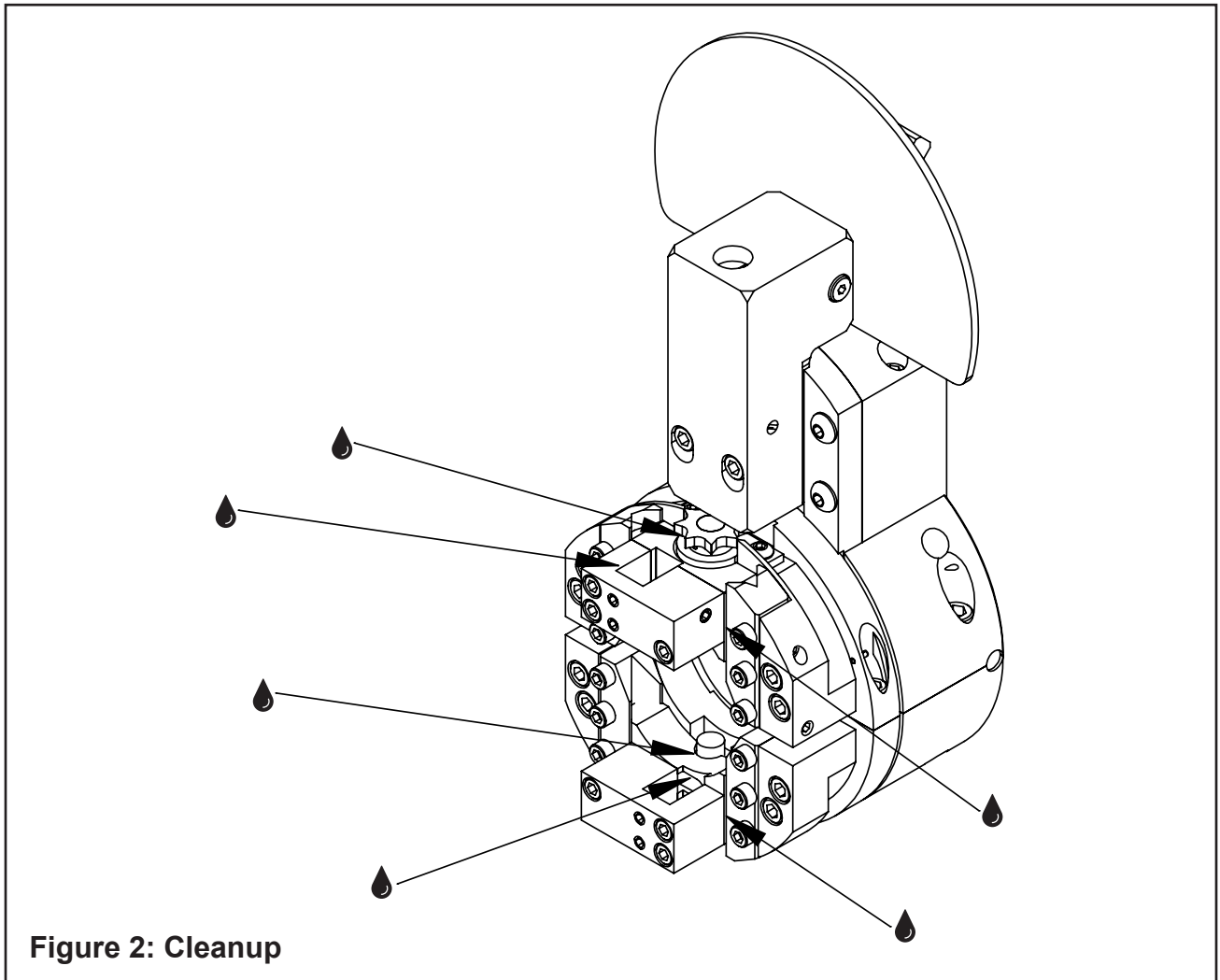

Figure 2: Cleanup

If the Clamshell is operated in such a manner that the Tool Blocks collect debris while cutting, the Tool Blocks and the Feed Screws should be cleaned after each cutting operation.

Recommended Maintenance Schedule

Daily Maintenance When the Unit Is In Operation

Wipe the unit down and spray with rust preventative under severe humidity conditions.

Visually inspect for loose screws, missing screws, damage, etc.

After Every 20 Hours of Actual Operation

Check adjustment of the Main Bearing pre-load. Drive torque as measured at the Drive Socket should be 5 to 10 ft-lbs. (7 to 14 N-m)

Lubricate the male and female Tool Block Slides and the Feed Screw.

After Every 40 Hours of Actual Operation

Thoroughly clean and lubricate Main Gear, Drive Gear, male and female Tool Slides, Feed Screws, and Tripper Block Assembly.

Non-Scheduled Maintenance

Readjust the Main Bearing pre-load if the Clamshell generates excessive heat or if the Main Bearing becomes loose.

Thoroughly clean and check the Tool Blocks in the event of feed problems.

Storage

If the Clamshell is to be stored, or if it will remain out of service for a significant period of time (30 days or more), it should be thoroughly cleaned, lubricated and sprayed with a rust preventative prior to storage.

Remove the airline quick disconnect and spray it with a lightweight oil. Squirt oil into the male quick disconnect.

Reconnect the airline and turn on the Air Motor for one (1) or two (2) seconds to disperse oil throughout the vanes and rotor.

Adjustment Of the Main Bearing Pre-Load

Loosen all Bearing Adjustment Lock Screws (all letters). Refer to Figure 3.

Loosen all Bearing Adjustment Set Screws (all numbers) about one half (1/2) turn.

Turn in Bearing Adjustment Set Screws (1, 3, 5, 7) so that they are snugged tightly. This ensures that the Bearing is fully pushed forward.

Lightly turn in the remaining Bearing Adjustment Set Screws (2, 4, 6, 8) in numerical order, until they all touch the Bearing.

Relax Bearing Adjustment Set Screws (1, 3, 5, 7) and re-snug them so that all of the Bearing Adjustment Set Screws are evenly loaded against the Bearing.

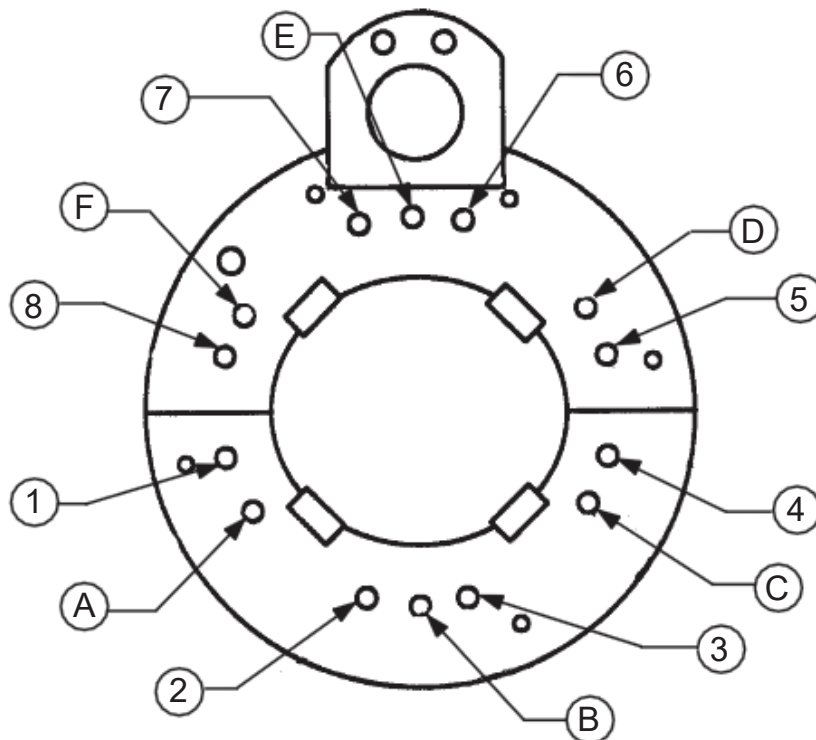

Figure 3: Bearing Adjustment Screw Locations

Connect the air supply and apply power to the Clamshell so that it is running at full speed.

Adjust the Bearing Adjustment Set Screws so that the Clamshell rotation slows slightly.

Listen for a change in the sound of the Air Motor.

Adjust the Set Screws in small increments so that the Bearing is loaded evenly.

All of the Set Screws should be snugged to ensure that the Bearing is uniformly loaded.

Drive torque as measured at the drive socket should be 5 to 10 ft-lbs. (7 to 14 N-m).

The safe torque range on the Bearing Adjustment Set Screws is 1 to 3 in-lbs. (.1 to .3 N-m).

Over-tightening the Bearing Adjustment Set Screws will result in accelerated Bearing wear and lower available power.

Lock the Bearing pre-load by tightening the Bearing Adjustment Lock Screws (identified by letters).

The safe torque should be 8 to 10 ft-lbs. (11 to 14 N-m).



WARNING

WARNING: Too much torque may crack the Bearing while too little torque may allow the Bearing pre-load to relax.

Inspection of the Main Gear

If the Headstock does not run smoothly, even after adjustment, inspect the main gear to ensure that no chips, dirt or dust have damaged the gear.

Remove both front Thrust Plates by removing the Hold-down Screws.

Lift the Headstock from the Housing.

The Main Gear and the Main Bearing may now be inspected.

Check the Bearing, Housing, and the race on the Gear.

All surfaces should be smooth, without scratches, and they should feature even wear patterns over the entire surface.

Check the Housing cavity for chips, dirt and/or corrosion.

To reassemble, wipe clean all of the Bearing surfaces and clean the Housing cavity. Regrease the Gear using a lubricant approved by Tri Tool Technologies.

Place the Headstock carefully back into the Housing.

Bolt the Front Thrust Plates back into place.

If the bearing pre-load was properly adjusted before disassembly, then it will still be adjusted when reassembled.

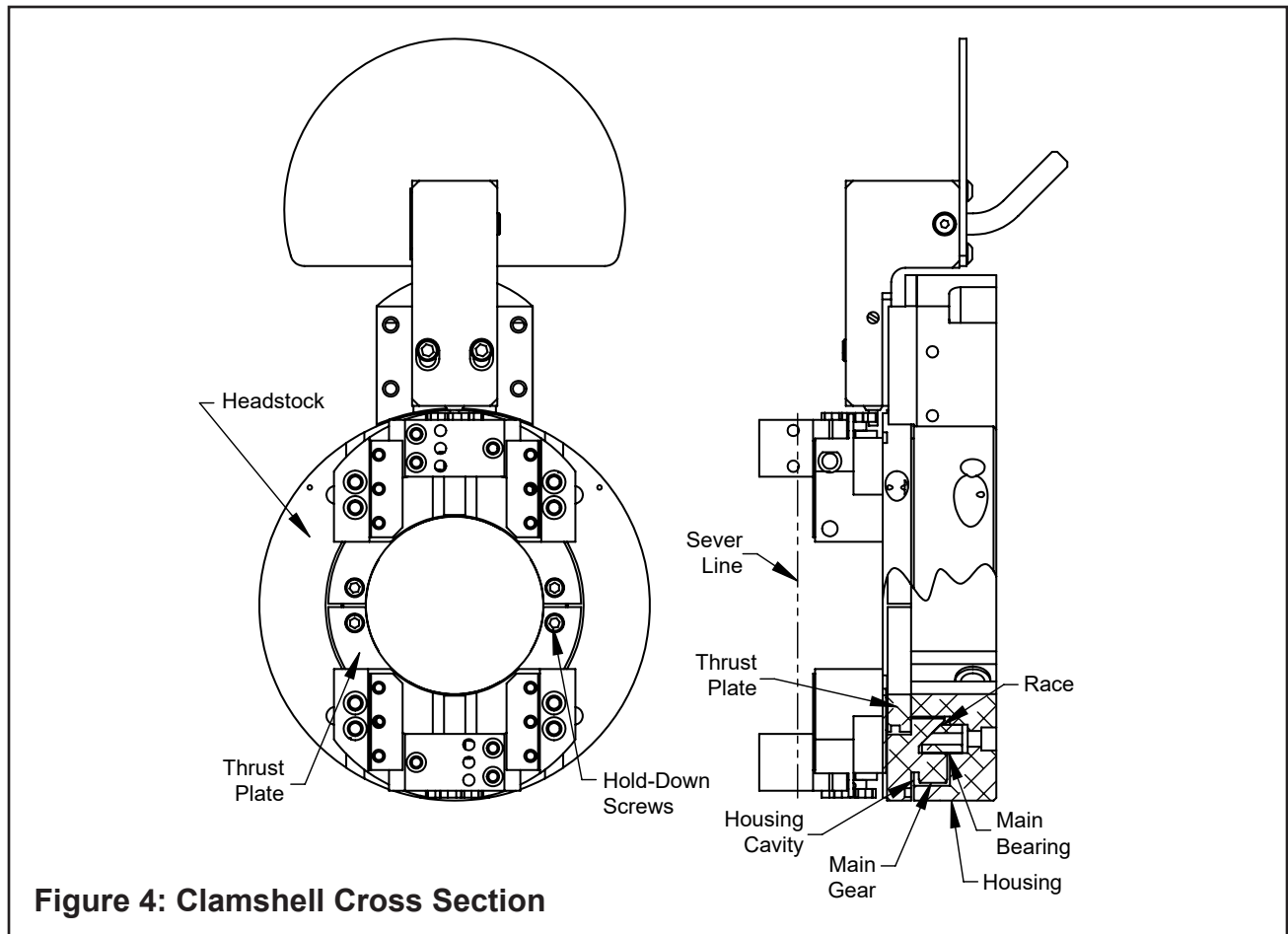

Drive Gear and Main Gear Lubrication

Remove the Drive Housing.

Inspect both Drive and Main Gears for chips or burrs and clean as required.

Coat the teeth of the Drive Gear and the Main Gear with a grease which is approved by Tri Tool Technologies.

Tool Block Maintenance

Clean the Slide Rails, the Feed Nut, the Sprocket Assembly and the Feed Screw. Inspect these parts for damage and replace as required.

Lubricate and reassemble the Tool Block.

NOTE: Use lubricant on the Feed Screw sparingly, or wipe to a film condition. Excess lubricant will collect grit and/or chips and tend to cause a thread jamming and/or damage.

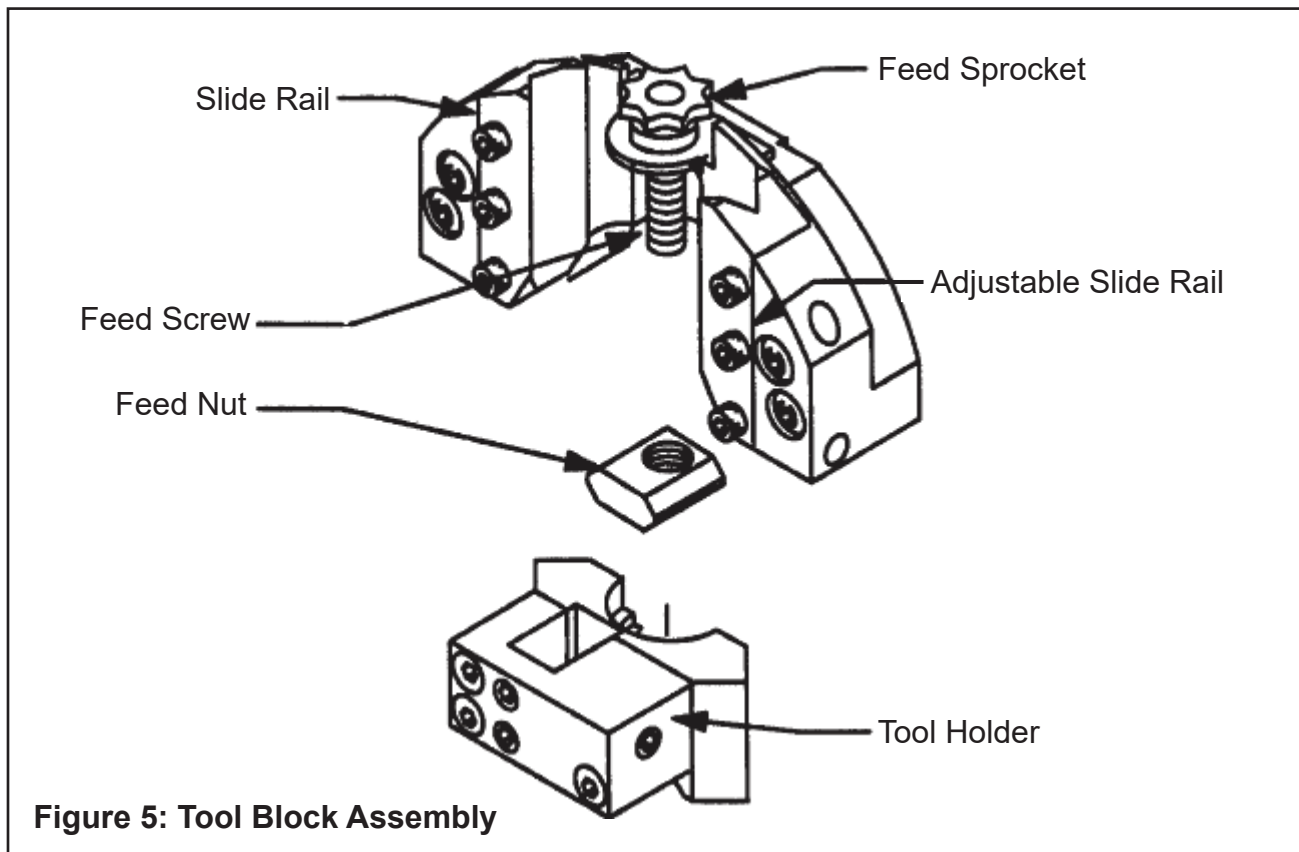

Figure 5: Tool Block Assembly

Adjust the Adjustable Slide Rail to provide a firm, but not excessive rotational pressure on the Sprocket.

The Slide Rails must be overtightened to squeeze the oil into a thin film against the male and female surfaces of the Slide Rails.

Reset for proper operation.

NOTE: If the Mounting Bracket has been overstressed, the Slide Rails may appear to loosen when mounted if they were adjusted off the Clamshell.

Adjustment when mounted provides the most satisfactory results.

Tool Holder Adjustment

Loosen the Hold-down Screws on the Adjustable Slide Rail.

Run the Tool Holder to the most outward position.

Using the Adjustment Set Screws, apply light force to the side of the Adjustable Slide Rail so that it is in positive contact with the Tool Holder.

Adjust only those screws, which bear directly in line with the Tool Holder.

Tighten the Hold-down Screws to about 12 to 24 in-lbs. (1.4 to 2.7 N-m). Finger-tighten using a hex key.

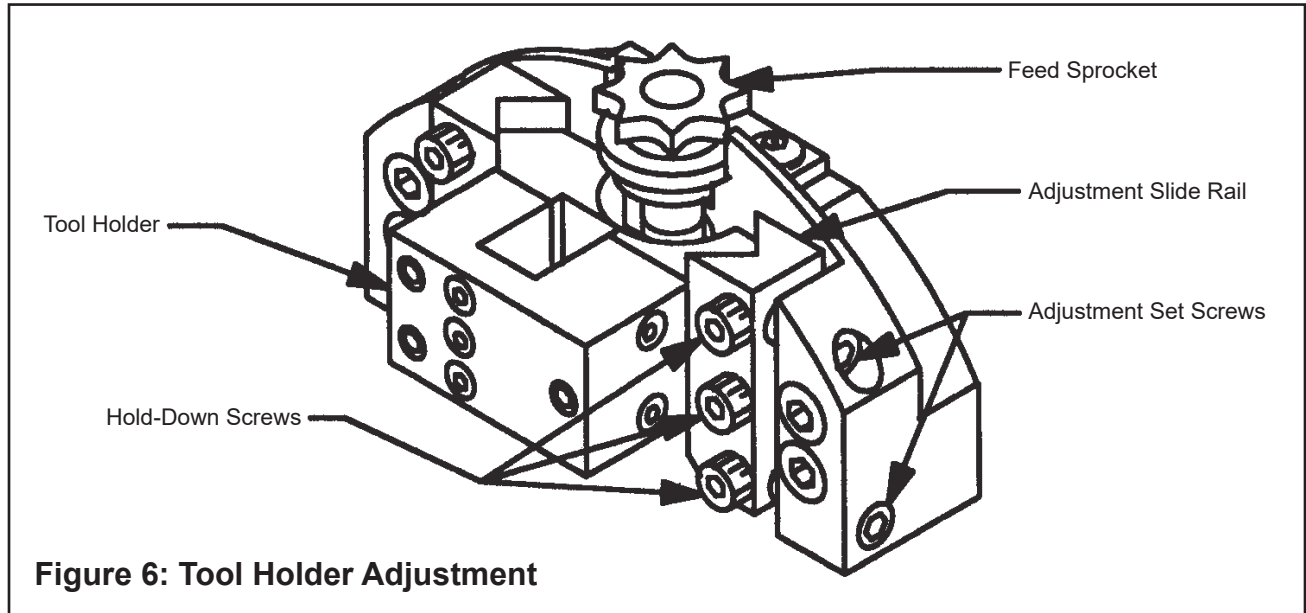

Using the Spanner Wrench, run the Tool Holder to the inward most position. Note any changes in the feed pressure.

Adjust the remaining Adjustment Set Screws so that the Tool Holder has a smooth, even feel. Run the Tool Holder the full length of the Slide Rail.

Tightly lock the Adjustable Slide Rail in place with the Hold-down Screws and fully snug the Adjustment Set Screws.

Check that the Tool Holder runs smoothly and evenly for the full length of travel. Re-adjust as necessary. The Tool Holder should move snugly.

In general, when the Slide Rail is set correctly, the Feed Sprocket cannot be turned by hand but may be turned easily with the Spanner Wrench.

The torque on the Spanner Wrench should be about 1 to 3 ft-lbs. (1 to 4 N-m).

Air Motor Lubrication

No direct maintenance is normally required on the Air Motor.

However, the air supply must flow through a Filter/Regulator/Lubricator (FRL) unit or separate units before arriving at the Motor.

The FRL unit must be maintained as required (frequency dependent on the basic air supply) to keep the water trap drained, filter cleaned, and the lubrication oil reservoir filled so that a drop of oil every 2 to 5 seconds is flowing.

If the Clamshell is to be left idle for 24 hours or more after being run on 'wet' air, it is advisable to squirt oil directly into the motor inlet and run the motor for two (2) to three (3) seconds. This will prevent rusting and 'freezing' of the rotor vanes.

Tripper Block Assembly Lubrication and Tripper Shaft Adjustment

Back off the Ball Plunger Set Screw until it disengages from the Tripper Shaft Assembly.

Remove the Shoulder Bolt, then remove the Tripper Lever.

Remove the Tripper Shaft Assembly from the block, then degrease and clean all parts.

Apply fresh lubrication to the Tripper Shaft Assembly and Shoulder Bolt.

Reassemble in reverse order.

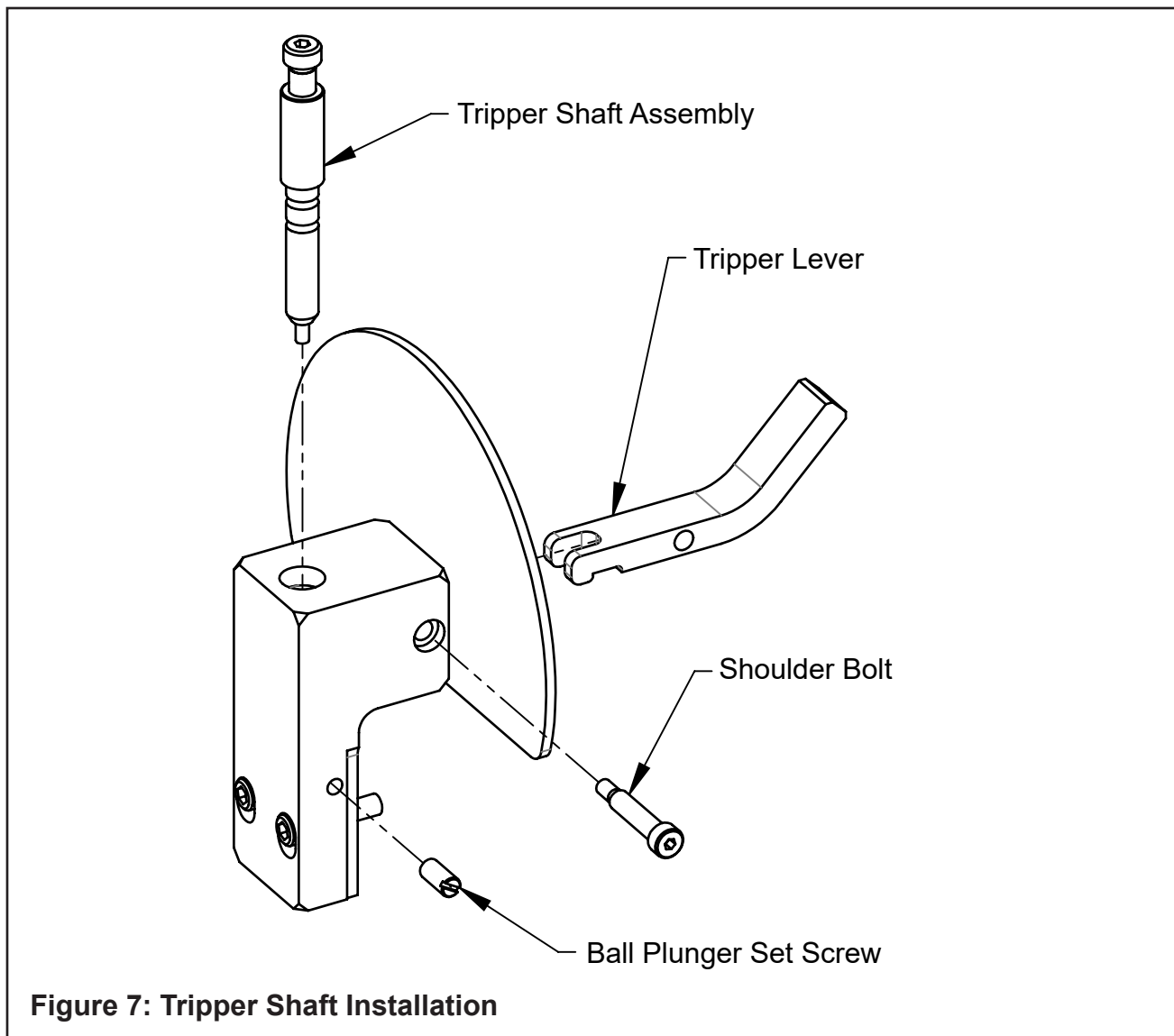

Lubricant Recommendations

The Drive Gears require a high string lubrication grease such as “Chevron Utility Grease, light, high string for gears” (P/N 68-0020).

The Slide Rails and Tool Blocks require a light oil such as SAE 10 light machine oil.

The Feed Screw for the Tool Block and the Tripper Block Assembly require a SAE 10 light machine oil for normal conditions, and under dusty conditions a silicone, graphite or molybdenum disulfide ‘dry’ lubricant.



WARNING

WARNING: A light film of all-purpose grease may be used, but it must be checked for grit contamination frequently.

The Air Motor requires a Class 2 lubricant, viscosity of 100 to 200 SSU at 100°F (38°C) minimum aniline point of 200°F (93°C).

- Tri Tool Technologies – Air Tool Lubricant (P/N 68-0022)
- AMOCO – American Industrial Oil no. 32
- Atlantic Richfield – Duro Oil S-150
- Chevron – A.W. Machine Oil 32
- Exxon – Nuto H32
- Shell – Tellus Oil 32

NOTE: The bearings in the Air Motor are sealed and do not require any lubrication.

6. OPERATION

Read the operating instructions carefully before attempting to operate the Model 602TSB Low Profile Clamshell.

See “Configure the Clamshell for Specific Task” later in this section to configure the machine.

Do not install the Tool Bits until the Clamshell is installed on the tube.

Installation of Clamshell On Inline Tube

1. Separate the two halves of the Clamshell.
2. Disengage the Air Motor by removing the Motor Hold-down Bolt and removing the Air Motor from the drive socket.
3. By hand, rotate the Headstock until the splitlines of the Headstock match the splitlines of the Housing.
4. Unbolt the two halves of the Clamshell.
5. Two Locking Screws are located on the Housing and two more on the Headstock. These Locking Screws are secured, thus avoiding the loss of parts.

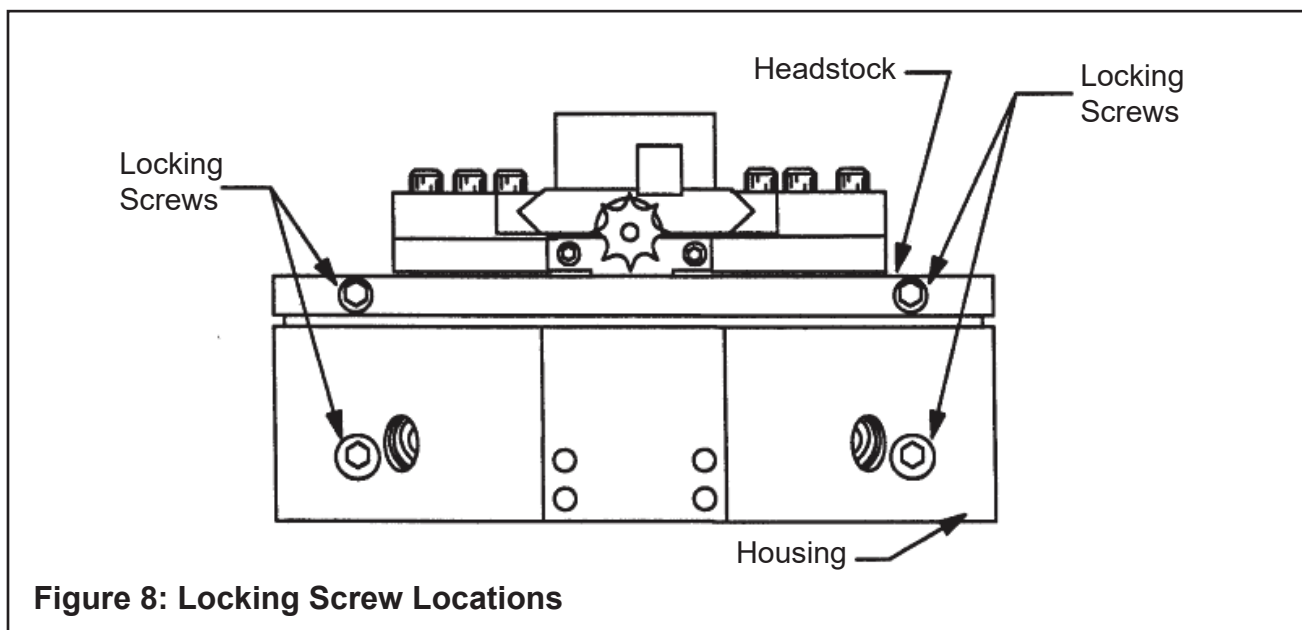

6. Separate the Clamshell halves evenly by pulling straight apart.



WARNING: DO NOT FORCE OPEN.

Secure the Clamshell to Tube

1. Clean the mating surfaces and the ID of the Clamshell halves.
2. Wipe clean the mounting surface of the pipe.
3. Check to ensure that the Tool Blocks will clear the tube when the Clamshell is mounted.
4. Close the two halves of the Clamshell around the tube, keeping the mating surfaces clean.
5. Check that the Alignment Pins have seated the two halves properly.
6. Bolt the two halves of the Clamshell together using the Locking Screws in the Housing and in the Headstock.

NOTE: Tightening torque should be 35 to 40 ft-lbs. (47 to 54 N-m).

Using Fixed Clamping Pads

NOTE: If using fully Adjustable Clamping Pads, go to the next section.

Clamp the Clamshell to the tube as follows:

1. Tighten the Clamping Pads lightly so that all of the Pads contact the tube.
2. Gently rock the Clamshell as you tighten the Clamping Pads to seat the Clamshell squarely on the tube.
3. Check that all four (4) Clamping Pads fully contact the tube. If not, repeat the last three steps.
4. Tighten the Clamping Pads. Tightening torque should be 40 to 50 ft-lbs. (54 to 68 N-m).
5. Go to “General Machining Sequence” later in this section.

Using Fully Adjustable Clamping Pads

Clamp the Clamshell to the tube as follows:

1. Rough center and square the Clamshell by tightening the Clamping Pads independently.
2. Check the center and squareness by eye.
 - The Adjustable Pads tend to square the Clamshell to the tube. If additional precision in squaring is required, consult Tri Tool Technologies about alternate methods of squaring.
3. Fine-center the Clamshell as you would a 4-jaw chuck.
4. Take measurements from the tube OD to the Housing ID, or use a dial indicator to sweep around the tube's outside diameter.
5. Adjust the four (4) Clamping Pads so that the measurements at opposing Clamping Pads are the same.

General Machining Sequence

To set Tool Bits, go to "Tool Bit Setup" later in this section.

Install the Air Motor into the drive socket and bolt it to the Clamshell.

There are six (6) alternate orientations available so that clearance for the Air Motor may be obtained (refer to Fig. 9).

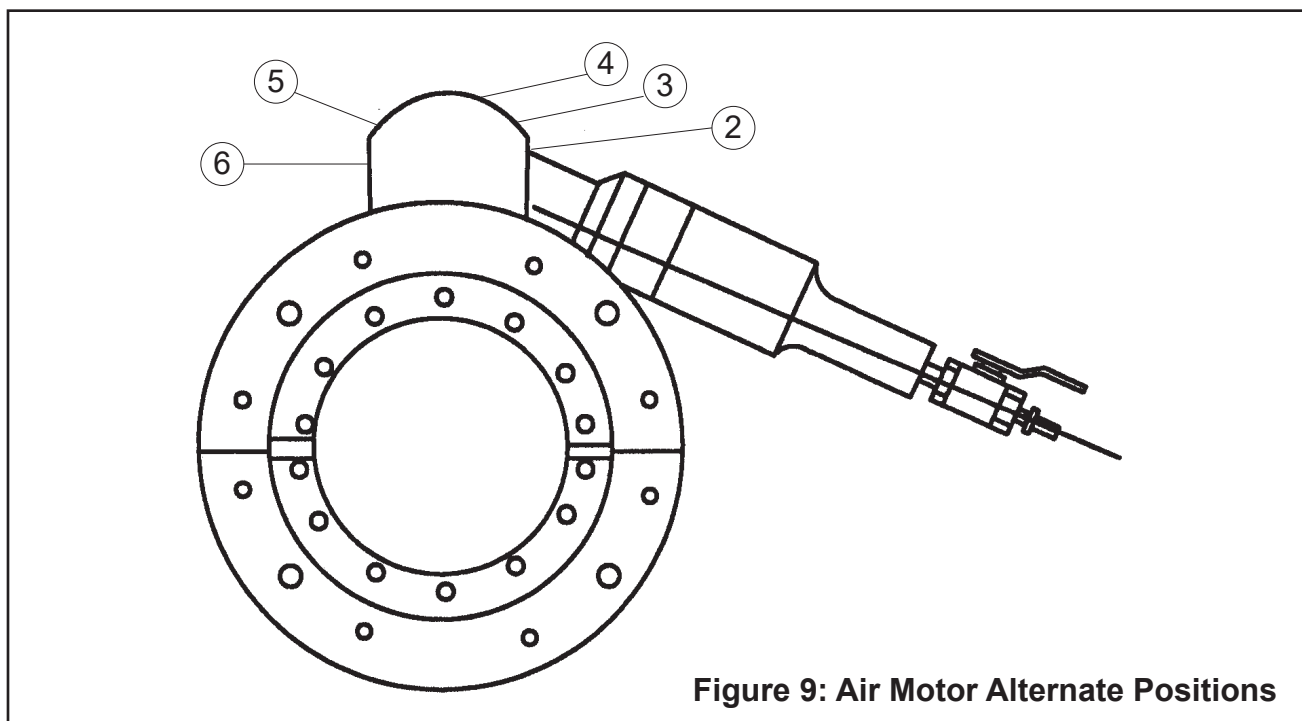



CAUTION: The Motor Mount reacts to the torque of the Air Motor only when the Motor Hold-down bolt is in place.

NOTE: Check that the air supply Filter/Regulator/Lubricator (FRL) is installed and set properly.

Check for proper alignment of the Feed Sprockets.

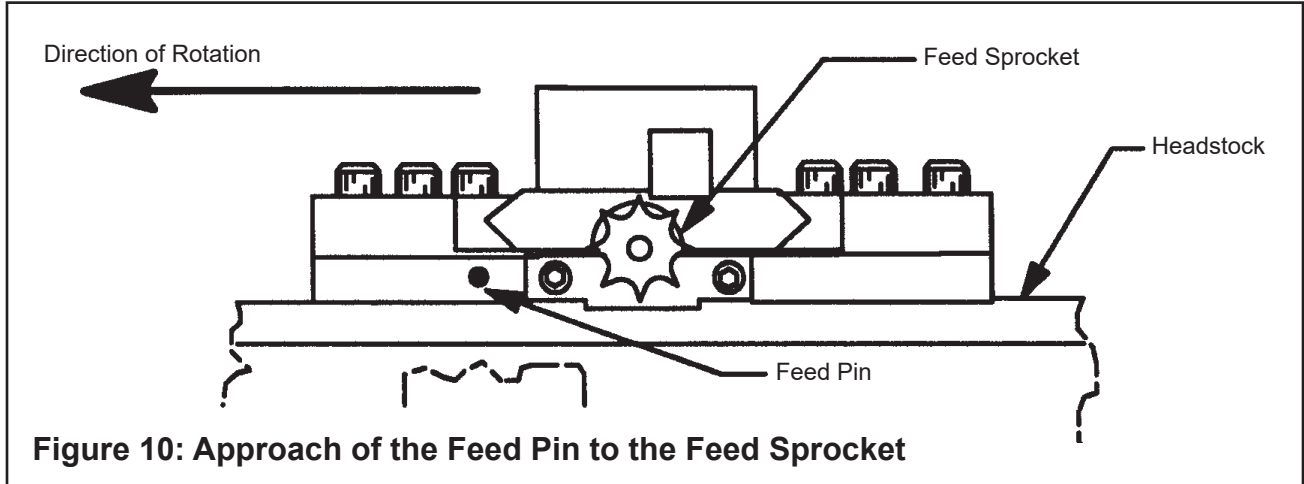

Run the Headstock slowly with the Feed Pin 'in' to ensure that the Sprocket is set correctly (do not run at full speed during the first revolution.)



WARNING: You will break the Feed Pin if the Feed Pin to Sprocket alignment is incorrect.

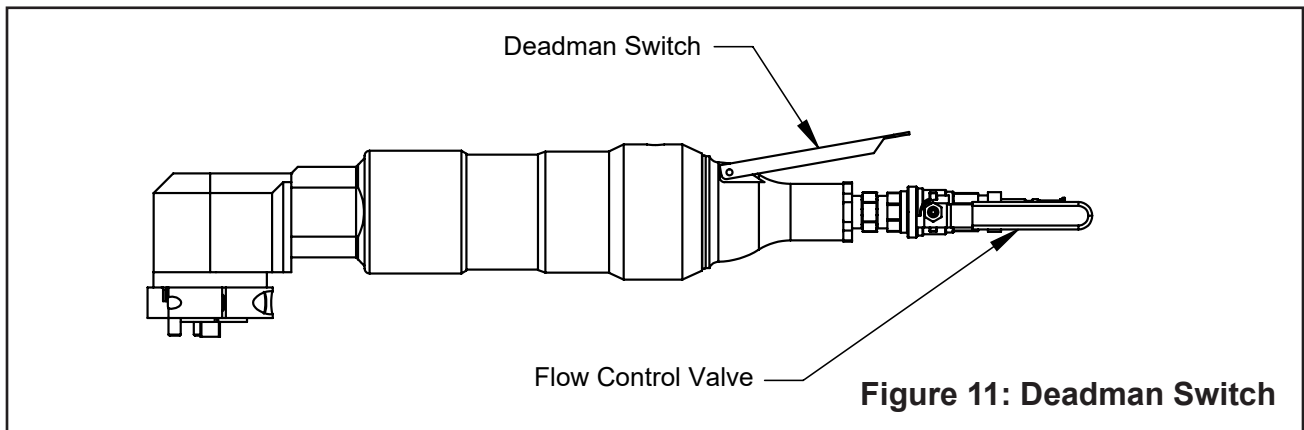

WARNING: Do not override the deadman switch on the power unit. Locking down, obstructing, or in any way defeating the deadman switch on the power drive unit may result in serious injury.

Turn on the Air Motor to full speed by opening the Throttle Control Valve.

NOTE: The Air Motor working speed will be about one half (1/2) of the no-load speed. Refer to the CUTTING SPEEDS section for speed selection charts.

Engage the feed by pushing the Tripper Shaft in.

Cutting Operation

1. Apply cutting fluid as necessary.
2. If chips build up so much that they tangle in the Clamshell, disengage the feed for 2-3 revolutions to clear the chip(s).
3. Stop the Clamshell and remove the chip(s).
 - See “Severing and Single Beveling or Severing and Double Beveling Simultaneously” later in this section for specific machining procedures.
4. When the machining operation is finished, turn off the Air Motor by closing the Throttle Control Valve.



CAUTION

CAUTION: Inline tube stores energy.

NOTE: When the tube is severed, it may move. To prevent accidents due to the spring in the tube system, be sure to secure the tube on both sides of the sever line in order to prevent differential movement of the tube ends.

5. Retract the Tool Holders so that the Tool Bit(s) clear the pipe OD.

NOTE: The Tool Holders are retracted by rotating the Feed Sprocket clockwise using the special Spanner Wrench supplied with the Clamshell.

6. Run the Air Motor until the splitlines of the Headstock and the Housing match.
7. Loosen the Clamping Pads.
8. Remove the Clamshell from the tube.

NOTE: If the Clamshell must be split to remove it, be sure that both halves are properly supported.

Configure the Clamshell for the Specific Task

Select the proper Tool Blocks (refer to the TOOL BLOCKS section).

Mount the Tool Blocks and Tripper Block to the Clamshell.

Check the adjustment of the slides and mesh of the Tripper Pin with the Feed Sprocket.

Select the proper Clamping Pad Set (refer to the CLAMPING PAD SETS section), and install the Clamping Pad Set into the Clamshell.

If using the Fixed Clamping Pad Set, then install the Clamping Pad Set so that the tube lays on the Fixed Pads or vice versa.

Fixed Pads should be located 90° from each other.

Pad Set Selection

Pipe Size	OD		P/N of Pad Sets
	2.000"	50.8mm	67-3152
1-1/2"	1.900"	48.3mm	67-3216
	1.875"	47.6mm	67-3217
	1.750"	44.5mm	67-3155
1-1/4"	1.660"	42.2mm	67-3218
	1.625"	41.3mm	67-3219
	1.500"	38.1mm	67-3220

Tool Bit Setup

1. Select the proper Tool Bit set (refer to the TOOL BITS section).



WARNING: Use of dull or improperly designed Tool Bits or Tool Bits not manufactured by Tri Tool Technologies may result in poor performance and may constitute abuse of this machine and therefore void the Tri Tool Technologies factory warranty.

2. Install the Tool Bits into the Tool Blocks. Refer to the TOOL BITS section for installation drawings.
 - Approximately .50" (12.7mm) should be protruding from the end of the Tool Holders.
3. Tighten the Tool Bit Set Screws, then verify that there is adequate clearance between the Tool Bits and the tube by rotating the Headstock by hand.
 - The Leading Tool Bit should contact the tube approximately .020" to .040" (.5mm to 1.0mm) before the Trailing Tool Bit.
4. Go to "Cutting Operation" earlier in this section.

Severing and Single Beveling or Severing and Double Beveling Simultaneously

When the Tool Bits are within about .040" (1.0mm) of severing the tube, disengage the Feed Pin and let the Headstock rotate 2-3 times to clear the chip.

Retract the Tool Holder which holds the Bevel Tool Bit, be sure that the Feed Sprocket is aligned properly.

Complete the sever.

After the sever is complete, reposition the Bevel Tool Bit so that it continues cutting until the desired land thickness is obtained.

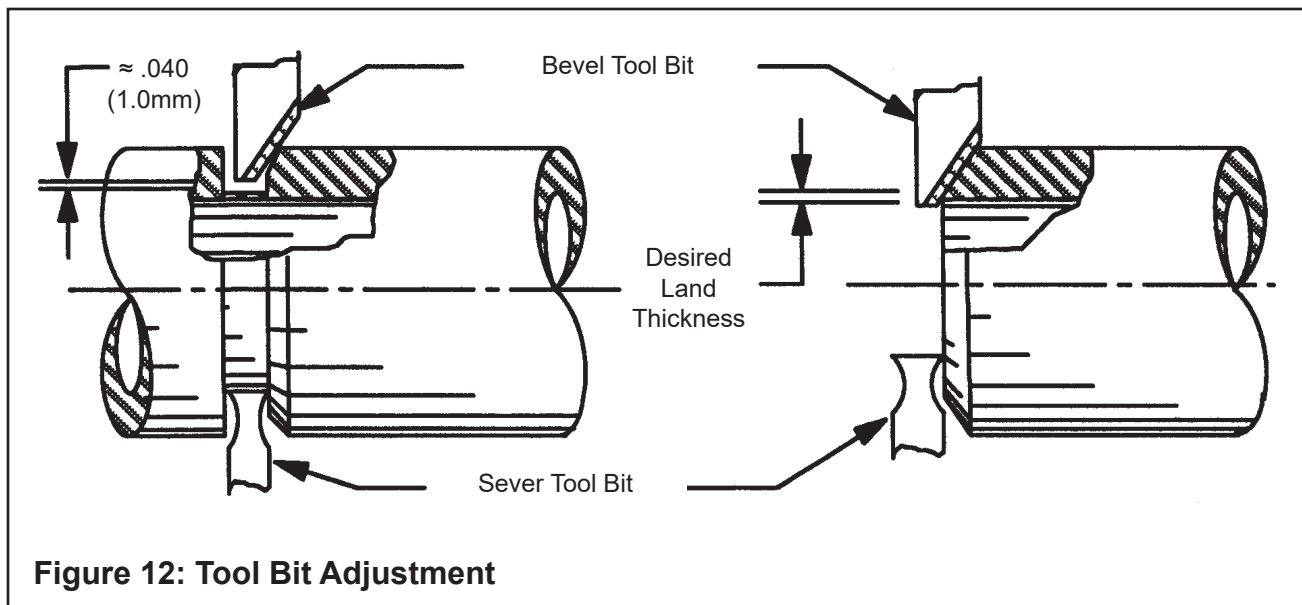

Figure 12: Tool Bit Adjustment

7. CUTTING SPEEDS

The chart shows RPM to obtain the specified Tool Bit surface cutting speed on the surface of the pipe.

True Diameter		RPM for 200 in/min (508 cm/min)	RPM for 250 in/min (635 cm/min)	RPM for 300 in/min (762 cm/min)
2.000"	50.8mm	32	40	48
1.750"	44.5mm	36	46	55
1.500"	38.1mm	42	53	64

Cutting Speeds (Approximate)

Use 200 surface inches per minute (508 surface centimeters per minute) for:

- Stainless steels in general when no coolant is allowed, all heavy-wall tube and some of the chrome/molybdenum steels.

Use 250 surface inches per minute (635 surface centimeters per minute) for:

- Mild steels and some thin wall stainless steels when coolants are permitted and applied.

Use 300 surface inches per minute (762 surface centimeters per minute) for:

- Aluminum and thin-wall mild steel and tube with coolants.

8. CLAMPING PAD SETS

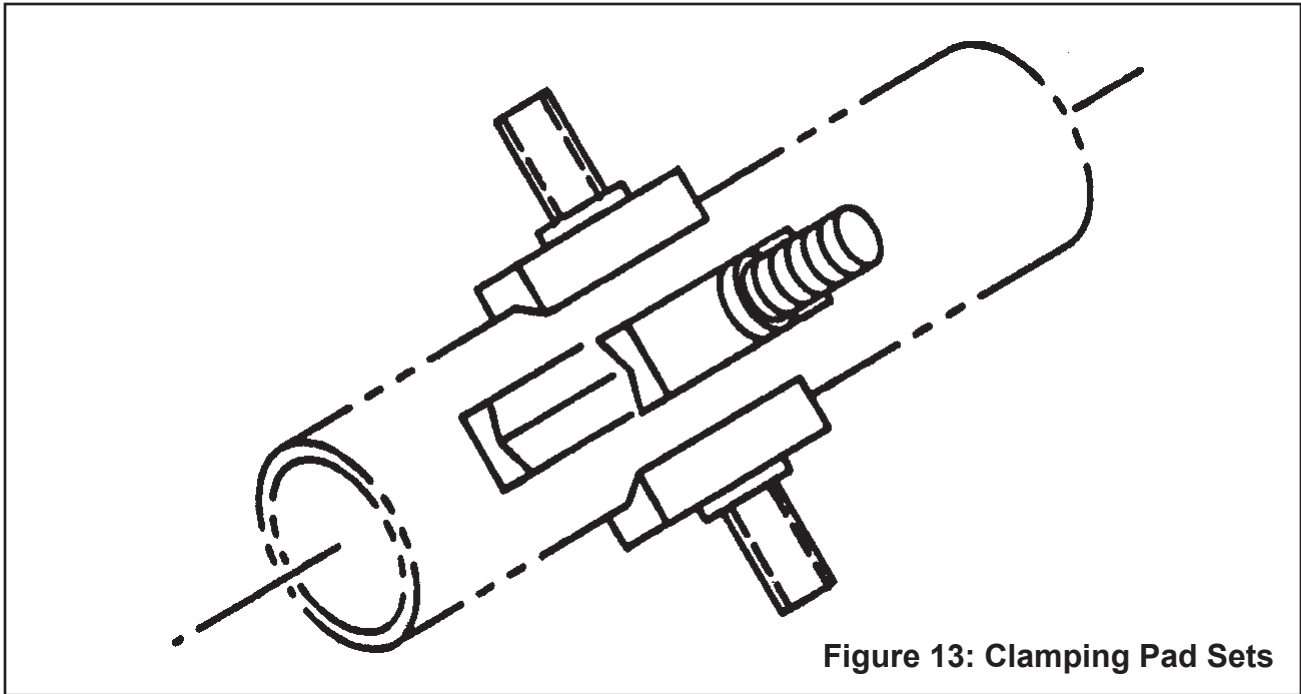

Figure 13: Clamping Pad Sets

Pipe Dia	True OD		Set Part No.	Adjustable Bar Assembly (2 REQ'D)	Fixed Bar Assembly (2 REQ'D)
	2.000"	50.8mm	67-3152	26-0560	26-0559
1-1/2"	1.900"	48.3mm	67-3216	26-0560	26-0348
	1.875"	47.6mm	67-3217	26-0560	26-0707
	1.750"	44.5mm	67-3155	26-0564	26-0566
1-1/4"	1.600"	40.6mm	67-3218	26-0713	26-0352
	1.625"	41.3mm	67-3219	26-0713	26-0709
	1.500"	38.1mm	67-3220	26-0715	26-0711

Contact Tri Tool Technologies for sizes not listed

9. TOOL BITS

Sever and Double Bevel Tool Bit Sets

Sever and Double Bevel Tool Bit Sets have been designed to leave a bevel on both pieces of pipe or tube that are being severed.

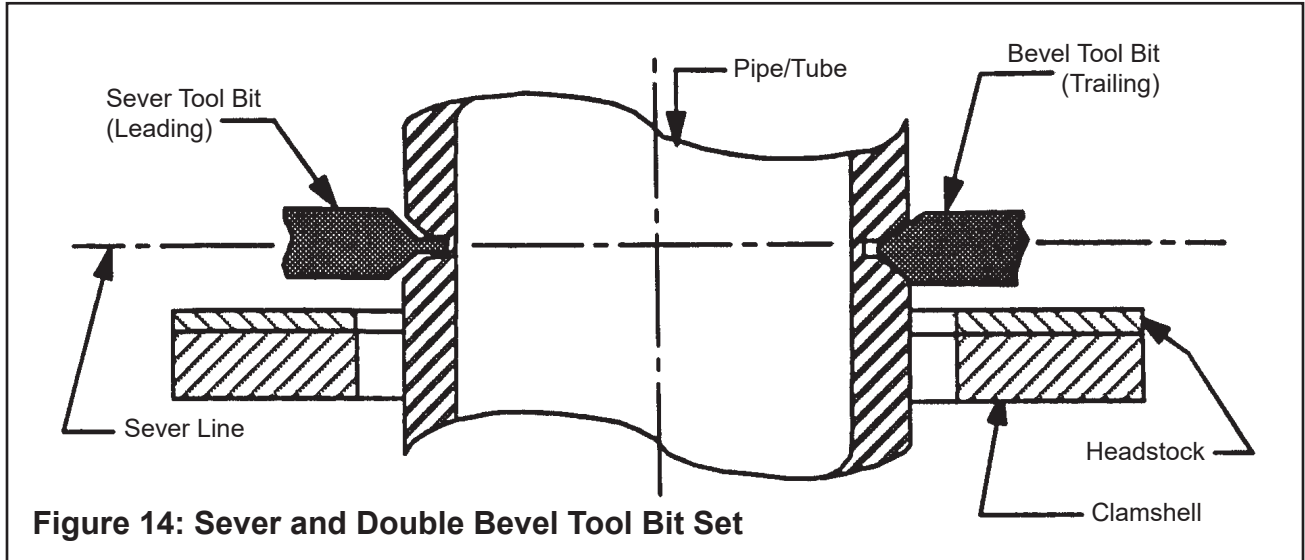

Sever and Double Bevel Tool Bit Sets

Range	Max Wall Thickness	Pipe or Tube Material	Double Bevel Tool Bit P/N	Sever Tool Bit P/N
-------	--------------------	-----------------------	---------------------------	--------------------

Sever and Double 30° Bevel Tool Bits

1.50" thru 2.00" OD Tube	.400"	10.2mm	CS, SS	99-2102	99-2103
--------------------------	-------	--------	--------	---------	---------

Sever and Double 37.5° Bevel Tool Bits

1.50" thru 2.00" OD Tube	.400"	10.2mm	CS, SS	99-4067	99-2103
--------------------------	-------	--------	--------	---------	---------

Sever and Bevel Tool Bit Sets

Right Hand Sever and Bevel Tool Bit Sets have been designed to bevel the end of the tube on which the Clamshell is mounted.

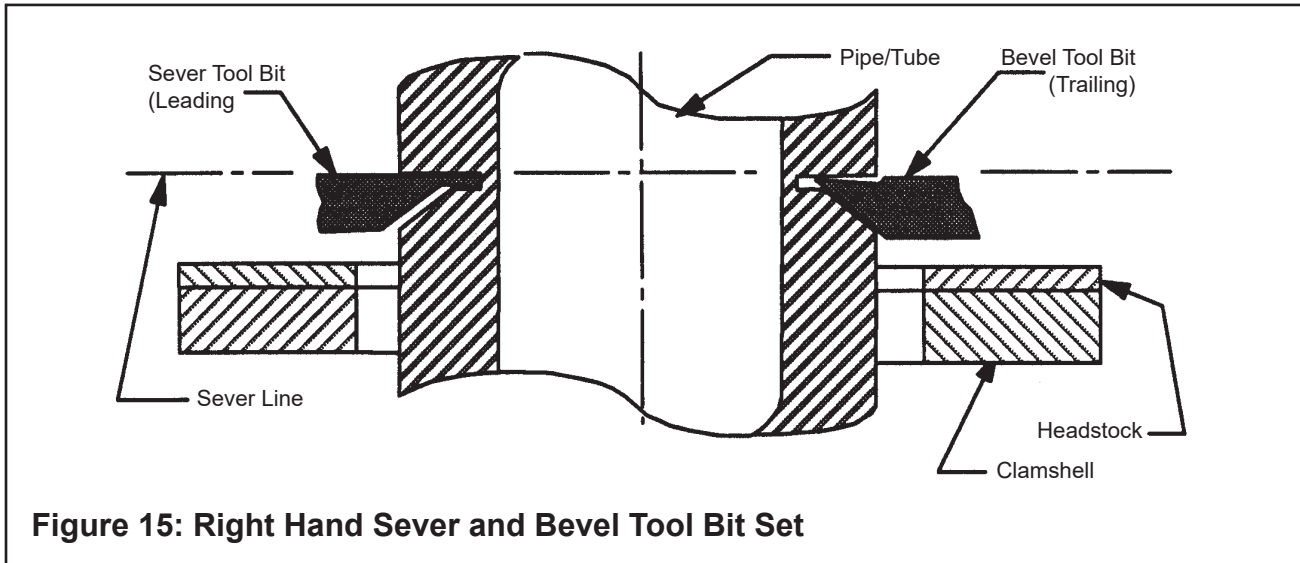

Figure 15: Right Hand Sever and Bevel Tool Bit Set

Right Hand Sever and Bevel Tool Bit Sets

Range	Max Wall Thickness	Pipe or Tube Material	RH Bevel Tool Bit P/N	Sever Tool Bit P/N
-------	--------------------	-----------------------	-----------------------	--------------------

Right Hand Sever and 30° Bevel Tool Bits - Use with a Spacer (P/N 30-0699)

1.50" thru 2.00" OD Tube	.400"	10.2mm	CS, SS	99-2172	99-2173
--------------------------	-------	--------	--------	---------	---------

Sever Tool Bit Sets

Right Hand Sever Tool Bit Sets have been designed to sever the pipe or tube close to the Clamshell relative to the Tool Holder.

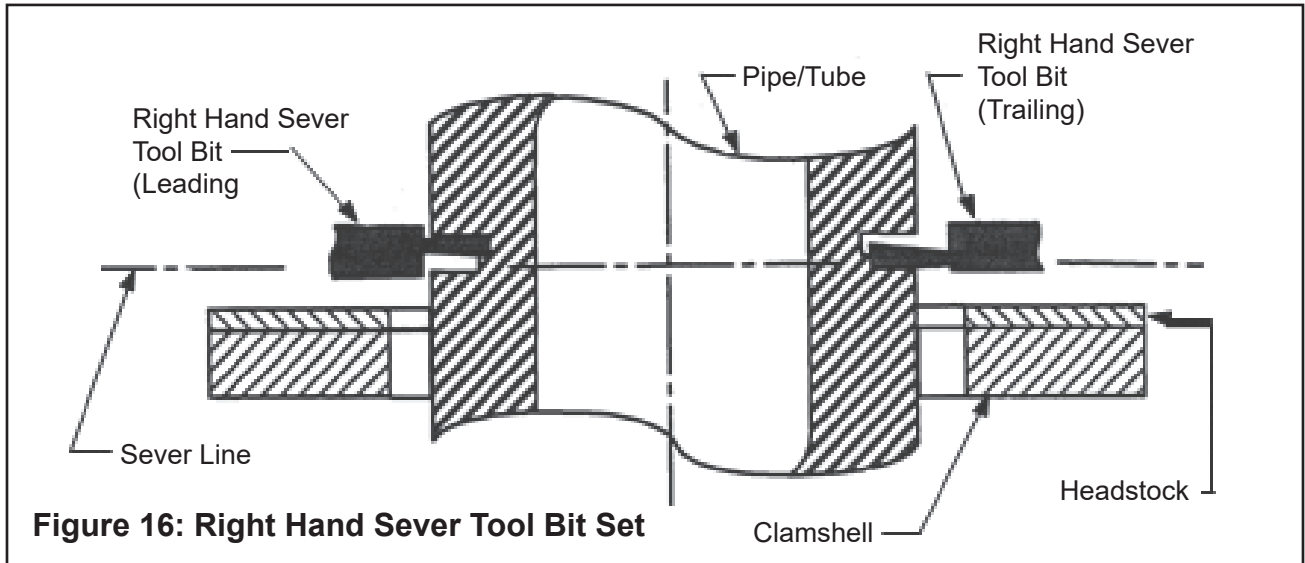

Right Hand Sever Tool Bit Sets

Range	Max Wall Thickness		Pipe or Tube Material	Leading Sever Tool Bit P/N	Trailing Sever Tool Bit P/N
1.50" thru 2.00" OD Tube	.400"	10.2mm	CS, SS	99-2100	99-2101

10. TOOL BLOCKS

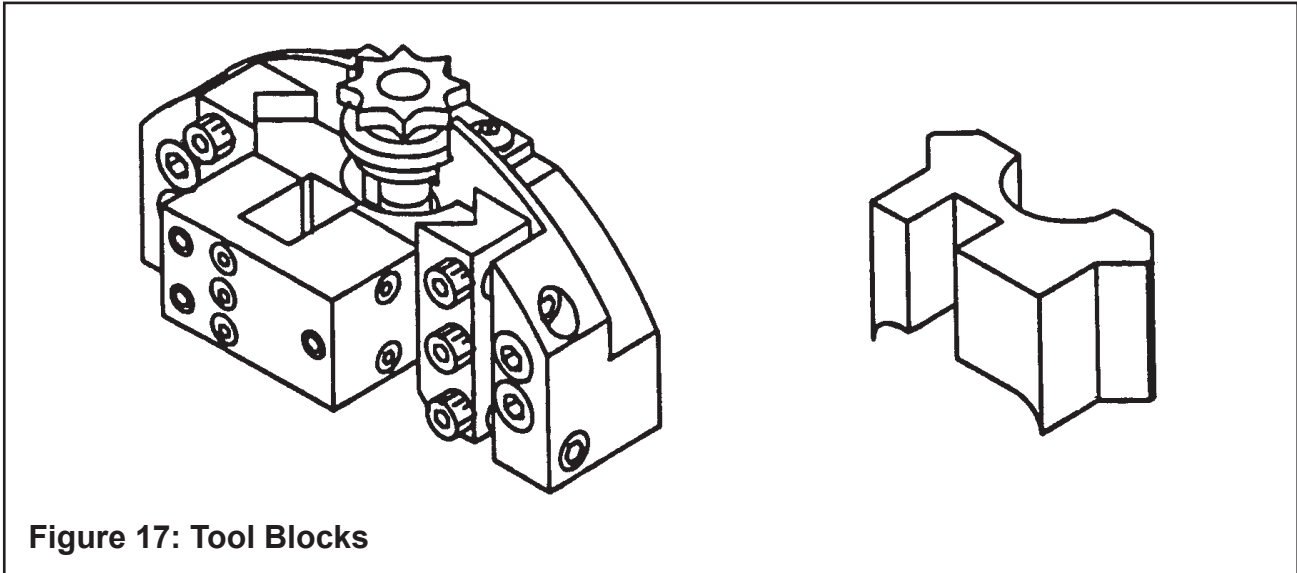

Tool Blocks

Part No.	Description
08-0107	Tool Block, Standard

11. TROUBLESHOOTING

Problem: Tool Bit Chatters

- The tool bit is loose or overextended.
 - The tool bit is damaged.
 - The tool holder is too loose in the slides.
 - The cutting speed is too fast.
 - The clamping pads are loose on the pipe or tube.
 - Cutting fluid is required.
 - The main bearing pre-load is loose.
-

Problem: Excessive Tool Bit Wear

- The pipe or tube material is too hard or abrasive.
 - The cutting speed is too fast.
 - Cutting fluid is required.
 - A dull Tool Bit is causing surface hardening conditions (Stainless pipe or tubing).
 - There is scale or other foreign matter on the pipe or tube, which is dulling the tool bit at the start of the cut.
 - The tool bit is incorrect for the material being cut.
-

Problem: Rough Surface Finish

- The tool bit is dull, chipped, etc.
 - Metal build-up on the cutting edge of the tool bit is creating a false cutting edge.
 - Cutting fluid is required.
 - The cutting speed is incorrect.
-

Problem: Tool Holder Is Not Feeding

- The feed pin is broken or out of position.
 - The feed sprocket shear pin is broken.
 - The feed screw is stripped.
 - The feed nut is stripped.
 - The slide rails are too tight.
-

Problem: Loss Of Air Power

- The air supply pressure is too low.
 - The air filter is plugged.
 - The air line size is insufficient.
 - The air line is too long.
-

Problem: Tool Bit Does Not Reach Work

- Incorrect tool blocks are installed for the size of the pipe or tube being worked on.
 - Incorrect tool bit is installed.
-

Problem: Air Motor Does Not Start

- The air power supply is shut off.
 - The air motor is damaged and will not run free.
 - The air motor needs lubrication. Add lubrication and do not run the air motor for a few minutes, then try running the motor.
 - Sand or other foreign material may be in the vanes of the air motor. Tap on the side of the air motor casing lightly with a piece of wood or with a soft rubber mallet just in case the vanes may be sticking.
-

Problem: Tool Bit Is Diving And Clamshell Is Stalling

- The Feed Pin is broken or out of position.
 - The Feed Sprocket shear pin is broken.
 - The Tool Bit is dull, chipped, etc.
 - The Tool Holder Adjustment Slide is too loose.
 - The Parting Tool Bit is leading the Beveling Tool Bit by too much for proper chip clearance.
 - The Tool Bit is over-extended.
 - The Main Bearing pre-load is too loose.
-

Problem: Headstock Is Hard To Rotate By Hand

- The Air Motor is still engaged.
 - The Clamping Pads are too tight on the pipe or tube.
 - Foreign material is on the mating surface of the splitlines.
 - Chips and/or other foreign material are in the rotating section.
 - The Tool Bit is in contact with the pipe or tube.
 - The Tool Block is in contact with the pipe or tube.
-

**Problem: The Clamshell Is Slipping On The Pipe Or Tube
(Fixed Pads)**

The Clamping Pads are not in full contact with the pipe or tube.

The clamping pressure is too light.

Scale and/or other foreign material is present on the pipe or tube.

Weld seams, swelling, or bumps under the Clamping Pads are preventing full contact.

Dull Tool Bits are causing extra force in the axial and/or radial direction.

The pipe or tube wall is too thin, which allows the tube wall to flex and the machine to move.

**Problem: The Clamshell Will Not Center On The Pipe Or Tube
(Fixed Pads)**

The Clamshell will not center on the pipe or tube. (Fixed Pads)

Incorrect Clamping Pad Set is installed.

Scale and/or foreign material is present on the pipe or tube.

One of the Clamping Pads is on a seam.

The pipe or tube has an out-of-round condition or is oversized or undersized.

12. ACCESSORIES

The following accessories are recommended for use with the Model 602TSB Clamshell and are available from Tri Tool Technologies.

- Portable Air Filter (P/N 75-0115)
- Tool Bits (refer to TOOL BITS section)
- Tool Blocks (refer to TOOL BLOCKS section)
- Clamping Pad Sets (refer to CLAMPING PAD SETS section)
- Lathe Stand Kit (P/N 60-0042)

NOTE: A portable Air Caddy Filter/Regulator/Lubricator (FRL) is required to protect the warranty on all Tri Tool Technologies air-driven tools.

13. ILLUSTRATED PARTS BREAKDOWN

MODEL 602TSB CLAMSHELL SUB-ASSEMBLY (P/N 02-2039)

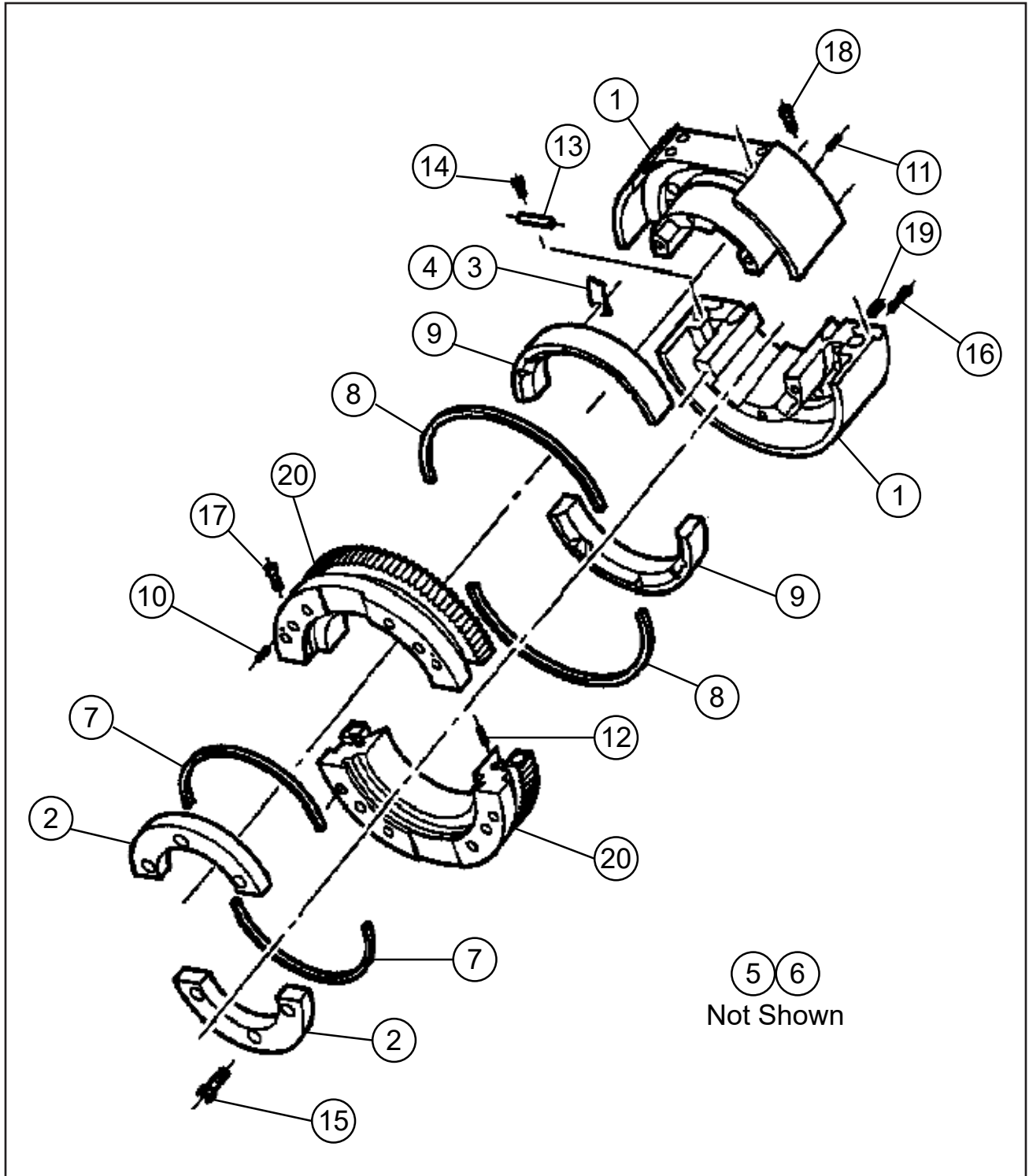

Parts List, Model 602TSB Clamshell Sub-Assembly (P/N 02-2039)

Item No.	Part No.	Description	Qty
1	19-0293	HOUSING, MAIN	1
2	24-0513	PLATE, THRUST	1
3	24-0515	PLATE, BEARING BACKING	2
4	24-0516	PLATE, BEARING BACKING	4
5		BAR ASSEMBLY, ADJUSTABLE*	2
6		BAR ASSEMBLY, FIXED*	2
7	28-0057	SEAL, FELT	12" (31 cm)
8	28-0057	SEAL, FELT	16" (41 cm)
9	29-0171	BEARING, MAIN	1
10	32-0008	PIN, ROLL, 5/64" DIA X 1/4"	2
11	32-0015	PIN, ROLL, 3/32" DIA X 5/16"	2
12	32-0153	PIN, DOWEL	2
13	32-0211	PIN, ALIGNMENT	4
14	33-0012	SCREW, CAP, 6-32 X 3/8"	4
15	33-0029	SCREW, CAP, 10-24 X 5/8"	6
16	33-0032	SCREW, CAP, 10-24 X 1"	6
17	33-0039	SCREW, CAP, 1/4-20 X 5/8"	2
18	33-0056	SCREW, CAP, 5/16-18 X 1"	2
19	33-1452	SCREW, SET, 5/16-24 X 5/8", HDOG	8
20	39-0286	GEAR, HEADSTOCK	1
<i>NOT SHOWN</i>			
	05-1081	SHIPPING KIT, 602TSB	1
	36-0003	WRENCH, L, 3/32" HEX	1
	36-0005	WRENCH, L, 1/8" HEX	1
	36-0007	WRENCH, L, 5/32" HEX	1
	36-0008	WRENCH, L, 3/16" HEX	1
	36-0010	WRENCH, L, 1/4" HEX	1
	36-0011	WRENCH, L, 5/16" HEX	1
	36-0018	WRENCH, T, 1/8" HEX	1
	36-0020	WRENCH, T, 5/32" HEX	1
	36-0021	WRENCH, T, 3/16" HEX	1
	36-0051	WRENCH, SPANNER	1
	60-0042	LATHE STAND	1
	86-0057	CARRYING CASE	1
		<i>*Refer to CLAMPING PAD SETS section for options</i>	

HOUSING ASSEMBLY, DRIVE (P/N 19-0291)

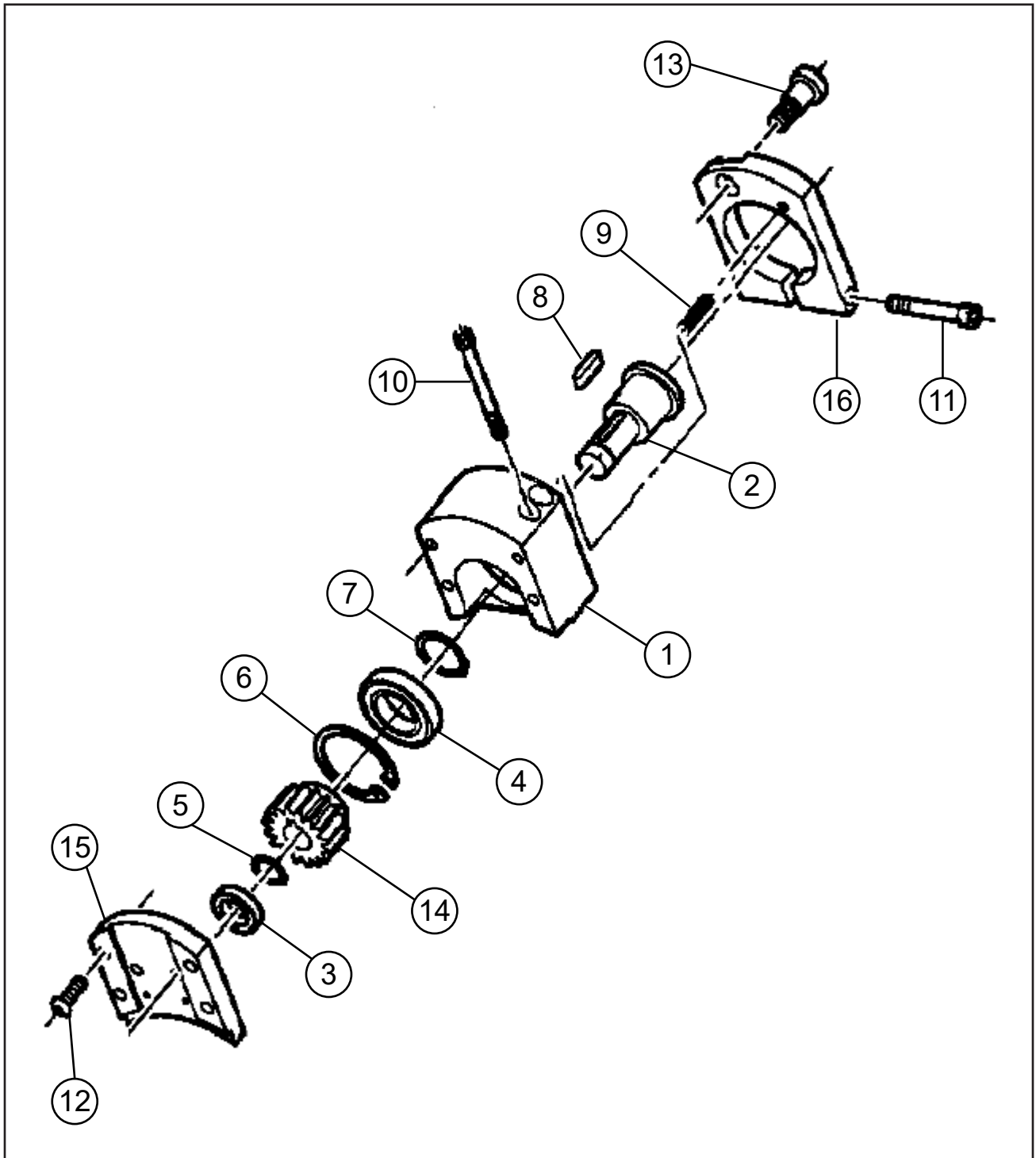

Parts List, Housing Assembly, Drive (P/N 19-0291)

Item No.	Part No.	Description	Qty
1	19-0211	HOUSING, GEARBOX	1
2	20-0199	SHAFT, DRIVE	1
3	29-0064	BEARING, BALL	1
4	29-0065	BEARING, BALL	1
5	30-0011	RING, RETAINING, EXTERNAL, 5/8" OD	1
6	30-0369	RING, RETAINING, INTERNAL, 1-3/4" ID	1
7	30-0411	RING, RETAINING, EXTERNAL 1" OD	1
8	31-0051	KEY	1
9	32-0024	PIN, ROLL, 8-32 X 1"	1
10	33-0048	SCREW, CAP, 1/4-20 X 2-1/2"	4
11	33-0060	SCREW, CAP, 5/16-18 X 2"	1
12	33-0287	SCREW, BUTTON, 1/4-20 X 3/4"	4
13	33-1451	SCREW, SHOULDER	1
14	39-0204	GEAR, DRIVE	1
15	43-0238	COVER	1
16	47-0363	BRACKET, TORQUE RESTRAINT	1

MOTOR ASSEMBLY, AIR (P/N 57-0126)

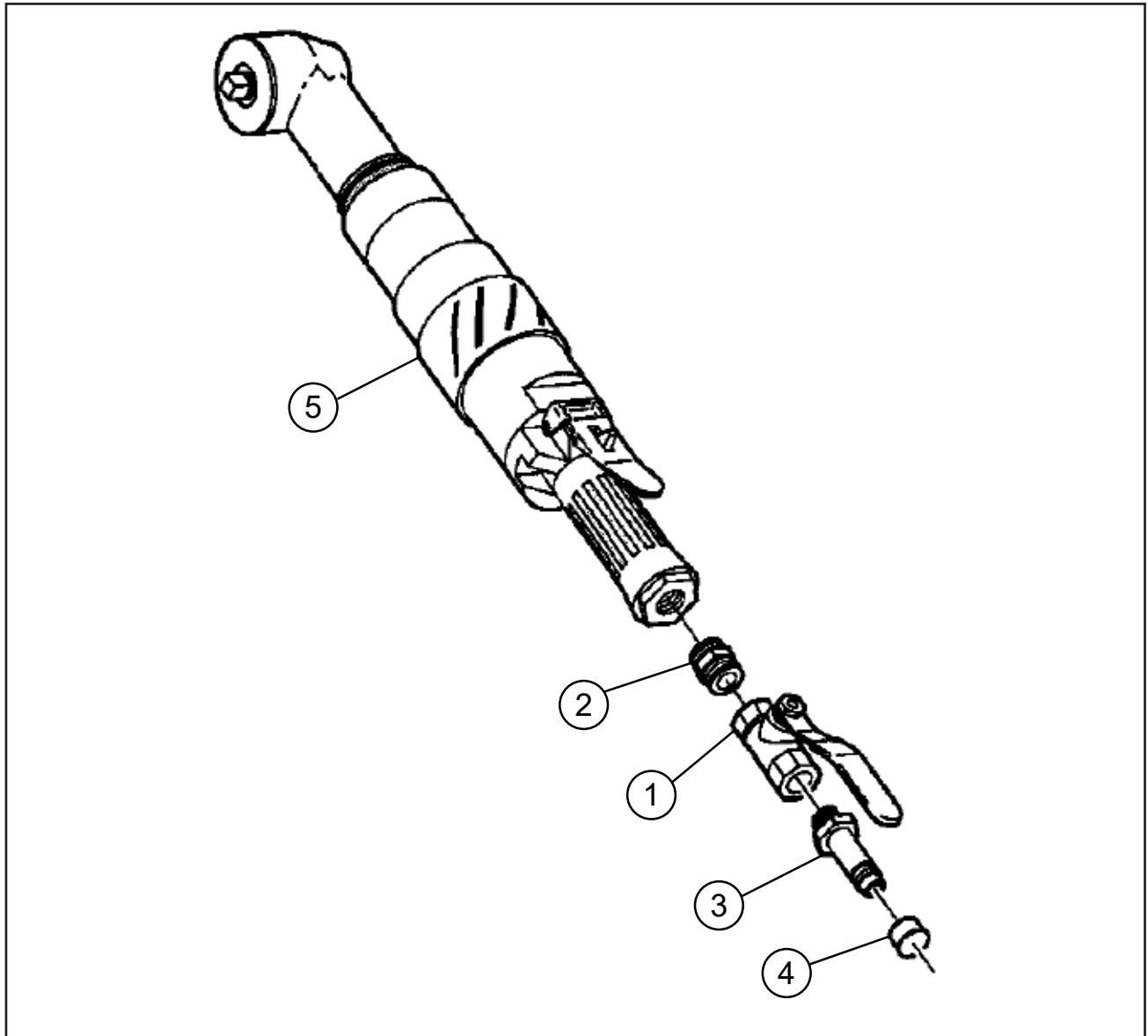

Parts List, Motor Assembly, Air (P/N 57-0126)

Item No.	Part No.	Description	Qty
	53-0031	VALVE ASSEMBLY, FLOW CONTROL	1
1	53-0016	VALVE, FLOW CONTROL	1
2	54-0019	NIPPLE, EXT PIPE TO EXT PIPE	1
3	54-0126	COUPLING, MALE, QUICK DISCONNECT	1
4	54-0201	CAP, PLASTIC	1
5	57-0075	MOTOR ASSEMBLY, AIR	1

TOOL BLOCK, STANDARD (P/N 08-0107)

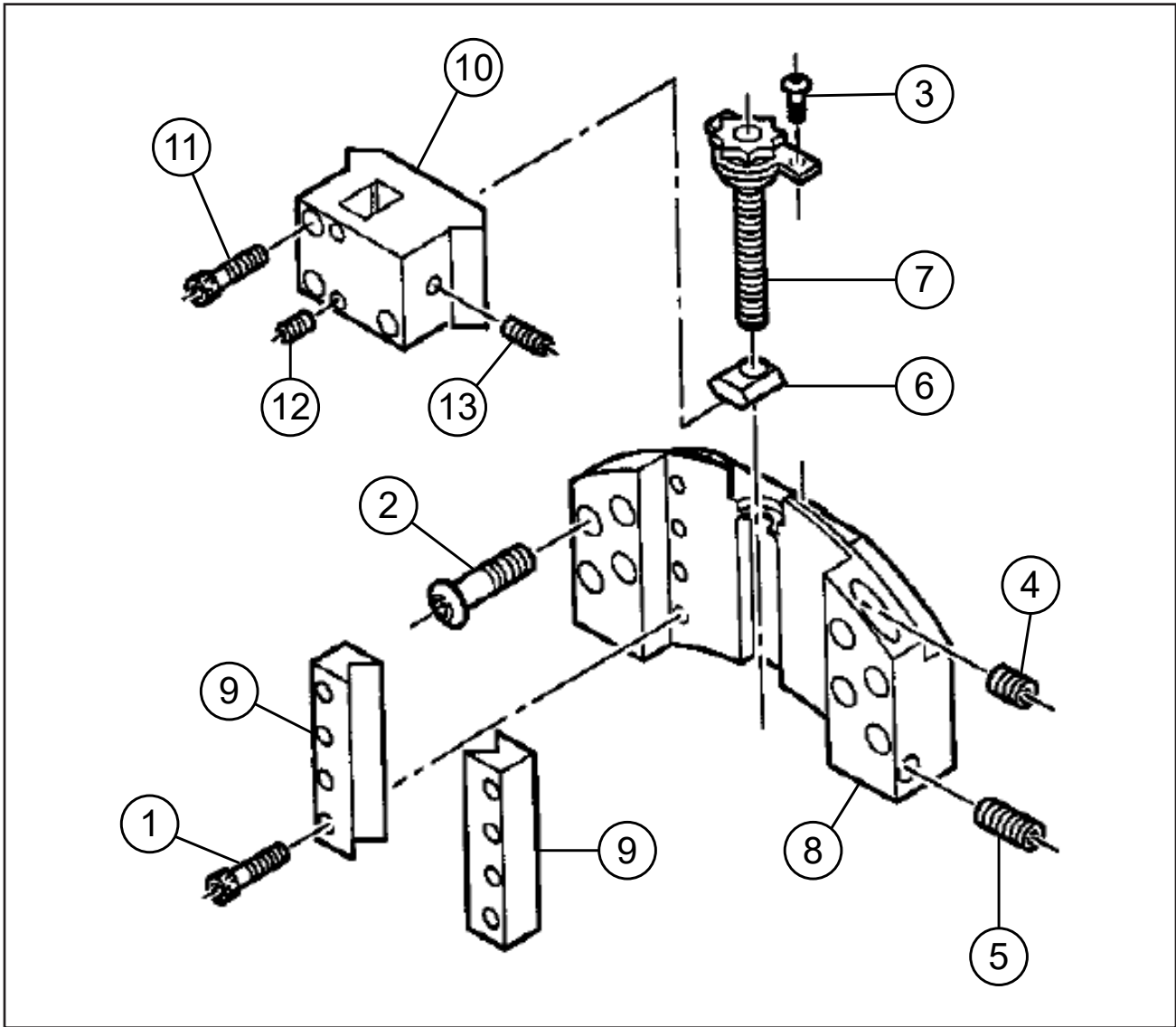

Parts List, Tool Block, Standard (P/N 08-0107)

Item No.	Part No.	Description	Qty
1	33-0032	SCREW, CAP, 10-24 X 1"	6
2	33-0043	SCREW, CAP, 1/4-20 X 1-1/4"	4
3	33-0279	SCREW, BUTTON, 10-24 X 1/2"	2
4	33-0631	SCREW, SET, 1/4-28 X 3/8", CUP PT	1
5	33-0634	SCREW, SET, 1/4-28 X 5/8", CUP PT	1
6	35-0176	NUT, FEED, 3/8-40 X 5/16"	1
7	38-0059	SPROCKET ASSEMBLY, FEED	1
8	47-0309	BRACKET, MOUNT	1
9	48-0354	BLOCK, GUIDE	2
10	49-0043	HOLDER ASSEMBLY	1
11	33-0204	SCREW, CAP, 10-32 X 1"	3
12	33-0500	SCREW, SET, 1/4-20 X 5/16", CUP PT	2
13	33-0505	SCREW, SET, 1/4-20 X 3/4", CUP PT	1

BLOCK ASSEMBLY, TRIPPER LEVER (P/N 47-2390)

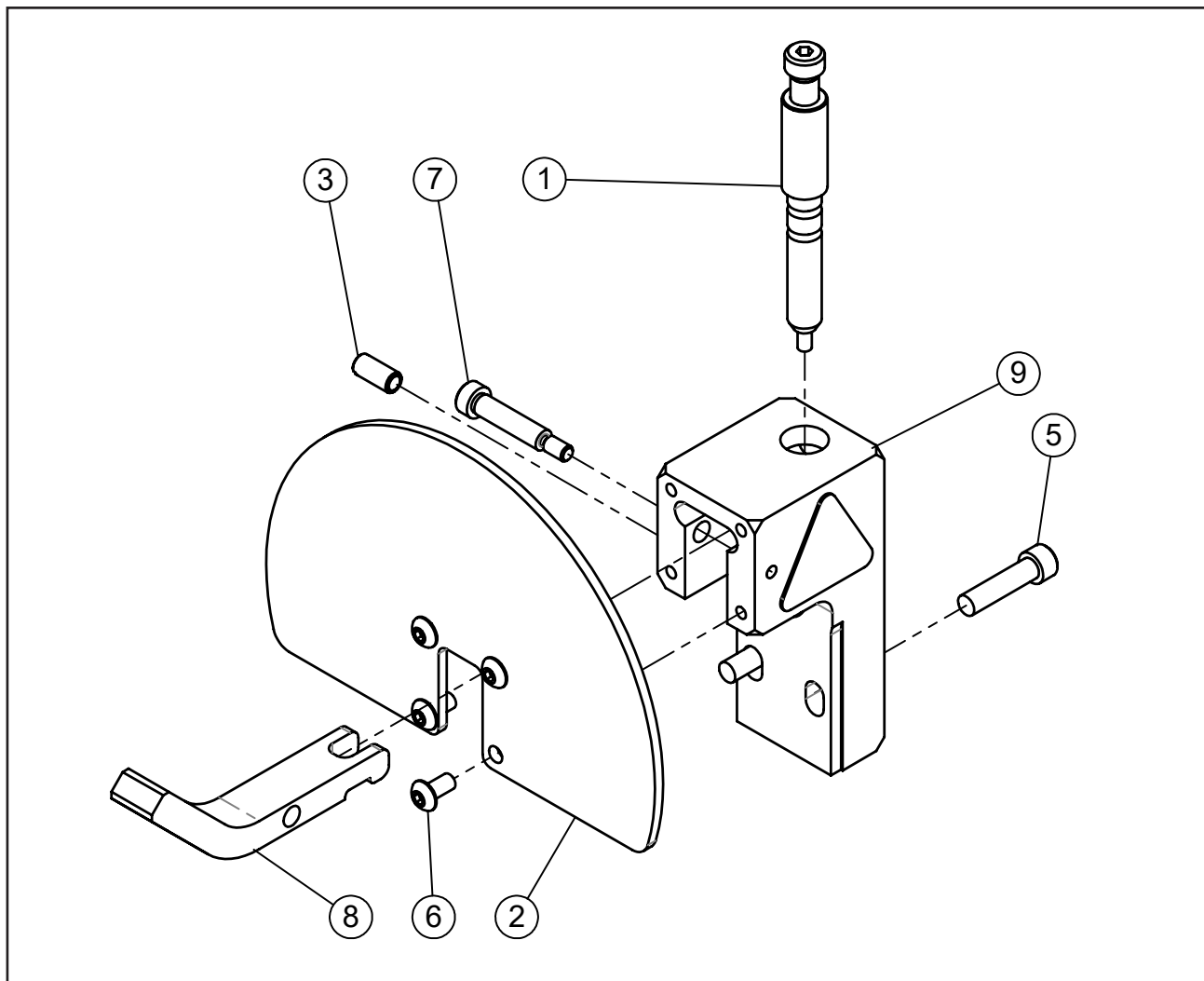

Parts List, Block Assembly, Trippler Lever (P/N 47-2390)

Item No.	Part No.	Description	Qty
1	14-0138	SHAFT ASSEMBLY, TRIPPER, SB	1
2	24-3901	GUARD, TRIPPER, SB	1
3	30-0125	PLUNGER, BALL, 1/4-20 X 17/32"	1
4	30-5686	LABEL, HAND CRUSH/TRIANGLE	1
5	33-0043	SCREW, CAP, 1/4-20 X 1-1/4"	2
6	33-0278	SCREW, BUTTON, 10-24 X 3/8"	4
7	33-1303	SCREW, SHOULDER, 1/4" X 1"	1
8	41-0246	LEVER HANDLE, TRIPPER, SB	1
9	47-2389	BLOCK, TRIPPER	1

14. RECOMMENDED SPARE PARTS

Parts List, Recommended Spare Parts for the Model 602TSB Low Profile Clamshell

Item No.	Part No.	Description	Qty
1	14-0138	SHAFT ASSEMBLY, TRIPPER	2
2	32-0126	PIN, FEED SPROCKET	2
3	33-0043	SCREW, CAP, 1/4-20 X 1-1/4"	8
4	33-0279	SCREW, BUTTON, 10-24 X 1/2"	4
5	33-0500	SCREW, SET, 1/4-20 X 5/16", CUP PT	2
6	33-0505	SCREW, SET, 1/4-20 X 3/4", CUP PT	2
7	35-0176	NUT FEED	2
8	38-0023	SPROCKET, FEED	2



WARNING



Read the manual and be familiar with all safety precautions before operating equipment. The following are general warnings for industrial equipment with moving parts. Refer to the manual for specific warnings applicable to your equipment.



EYE HAZARD - Always wear appropriate eye protection while operating the equipment.



PINCH HAZARD - Keep your hands and clothing away from moving parts.



CRUSH HAZARD - The machinery, pipe, or work piece can shift, separate, lurch, or fall.



CHIP HAZARD - Metal chips may be hot and sharp. Be careful when you clear the tooling path or clean up chips.



TIE DOWN HAZARD - Deliberate overriding of safety triggers can result in serious injury. Never lock or tie down any safety triggers.



SHOCK HAZARD - Ensure that the equipment is properly installed and grounded. Ensure that the equipment is not damaged and that the power cord is intact.

OTHER HAZARDS

- Tool bits are sharp and can cause serious injury.
- Do not defeat or modify safety features.
- Disconnect power sources before servicing or moving the equipment.
- Remove all loose articles of clothing and jewelry before operating the equipment.

Be Safety Conscious!



3041 Sunrise Blvd.
Rancho Cordova, CA 95742
+1(916) 288-6100 • +1(800) 345-5015
www.tritool.com