

TECHNICAL SPECIFICATION MODEL 604SB LOW PROFILE CLAMSHELL

The 604SB Low Profile Clamshell is a split-frame pipe lathe for severing and beveling inline pipe with a range of 2" through 4" pipe with minimal radial and axial clearances.

Design and Operating Features

- Easily adjustable precision bearing surfaces preload and stabilize the rotating head to provide long life, low maintenance, stability and precision.
- The Clamshell splits into two halves for mounting on closed looped systems. All parts are secured to the two halves to avoid loss of parts and provide maximum ease of handling.
- The machine may be equipped with self-centering mounting pads for quick, easy mounting or may be equipped with adjustable mounting pads for out-of-round pipe conditions.
- Dual tool modules with auto-feed sprockets and adjustable slide ways provide maximum maintainability, life and operator safety with minimum operator training.
- The auto-feed star sprockets provide .003" (.08 mm) of radial feed per revolution for a controlled depth of cut. A .001" feed module is also available.
- Drive gears and bearing surfaces are covered for operator safety and sealed to prevent cutting chip damage.
- Operator controls are away from the rotating headstock for safety.
- Modular design concepts provide quick, easy maintenance and maximum versatility in drive and tooling options.
- Detachable right angle air motor provides maximum handling ease and low axial clearance. Torque accepting mounting bracket allows the air motor to be rotated in various positions.

Specifications

Reference Envelope Drawing No. 77-0260

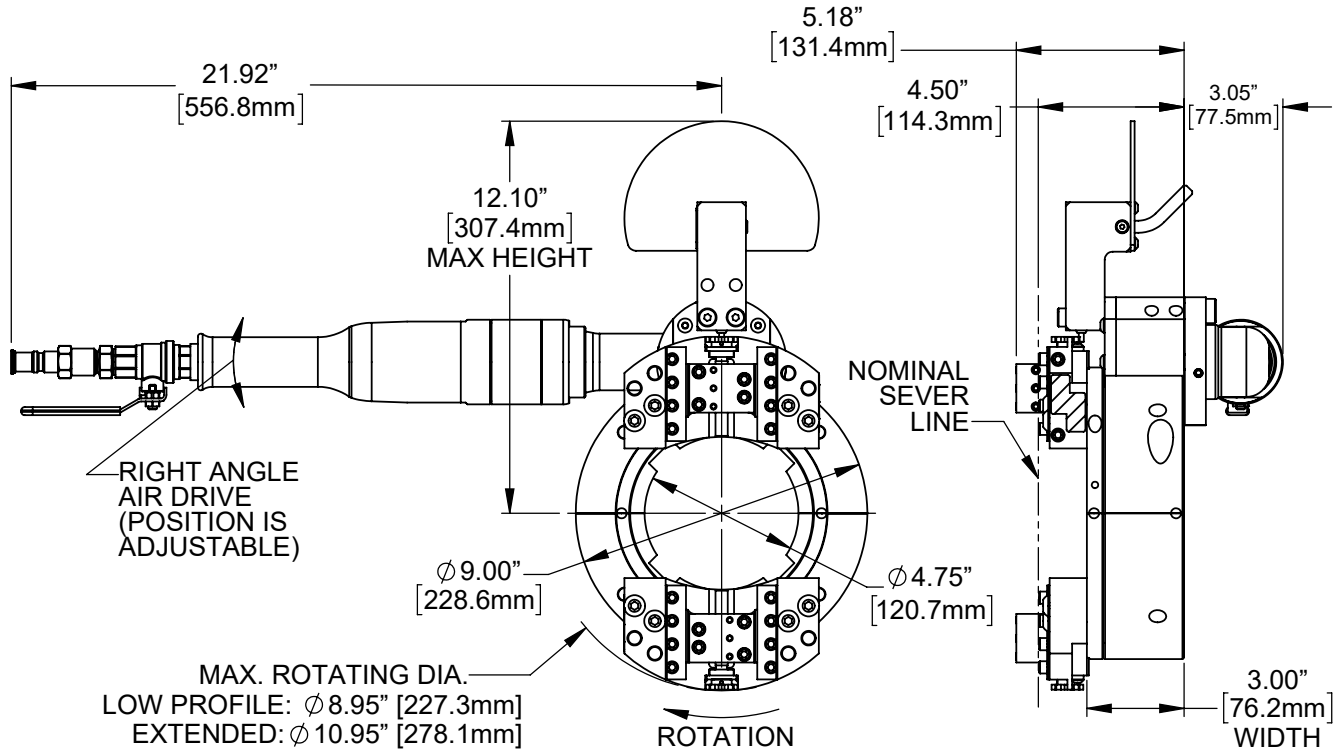

Weight

- | | |
|---|----------------------------|
| • Basic Machine | 24.0 lb (10.9 kg) |
| • Right angle drive air motor (standard duty) | 12.0 lb (5.5 kg) |
| • Low Profile Tool Module | 2.3 lb (1.1 kg) per module |
| • Extended Tool Module | 3.3 lb (1.5 kg) per module |
| • Stand for bench operation | 6.3 lb (2.9 kg) |

Cutting Capacities

Pneumatic Drive on 2" through 4" pipe

- | | |
|-------------------------------------|----------------------------|
| • Severing with standard procedures | Can go up to next schedule |
| • Severing and single beveling | .80" (20.3 mm) wall |
| • Severing and double beveling | Go down to next schedule |

Note: Capacity exceeds maximum wall thickness for small pipe sizes.

Electric Drive on 2" through 4" pipe for intermittent, non-continuous use

- | | |
|-------------------------------------|---------------------|
| • Severing with standard procedures | .75" (19.1 mm) wall |
| • Severing and single beveling | .50" (12.7 mm) wall |
| • Severing and double beveling | .38" (9.7 mm) wall |

Electric drive maximum wall thickness for continuous, production use**

Pipe Size	Sever Only	Sever and Single Bevel	Sever and Double Bevel
2"	N/A	0.84 inch	SCH XX (.436")
3"	SCH XX (.600)	SCH 160 (.438")	SCH 80 (.300")
4"	SCH 160 (.531")	SCH 120 (.438")	SCH 80 (.337")

***This data is calculated from test results in a controlled environment on carbon steel pipe with high speed tooling and without the use of coolant. Actual environment, pipe material, tooling, and operating conditions will impact motor performance.*

Information provided is for reference and discussion purposes only. Contact Tri Tool Technologies for more information.

Material Cutting Capabilities

Mild steels, chrome steels (Rc 35 max.), stainless steel, copper-nickel alloys and aluminum without limitations except size and wall thickness as specified.

Inconel and some other high temperature alloys may require special procedures as a function of wall thickness and type of end preparation. Contact Tri Tool Technologies for more information.

Drive Options

Right Angle Air Motor (Standard Duty)

- Air Requirements @ 90 psi (6.3 kg/cm²) 67 cfm (32 L/s)
- Head Speed @ maximum horsepower 25 RPM

Right Angle Air Motor (Heavy Duty)

- Air requirements @ 90 psi (6.3 kg/cm²) 85 CFM (40 L/s)
- Head speed @ maximum horsepower 19 RPM

Recommended when cutting wall thickness greater than:

- .75" (19.1 mm) for carbon steels
- .50" (12.7 mm) for stainless steels

Right Angle Drive Electric Motor (Light Duty)

- Power requirements (7.5 amp circuit) 115V (25 - 60 Hz)
- Head speed @ maximum horsepower 25 RPM

Inline Electric Motor (Heavy Duty)

- Power requirements (20 amps) 115V (40 - 60 Hz) or 230V (40 - 60 Hz)

Inline Hydraulic Motor (Special Order Only)

- Requires separate hydraulic power supply
- Power requirements 15 gpm @1500 psi (.94 L/s @ 10.34 kPa)

Speed Control

Hydraulic power source (Primary)

Flow control valve (Secondary)

Clamping

Fixed - Self-Centering Pad Sets

- All sizes within the specified size range are available upon request
- Adjustable pads available upon request

Tool Modules

Tool Module	Low Profile	Extended
Working Diameter Range	2.50" - 4.50" (63.5 - 114.3 mm)	0 - 4.50" (0 - 114.3 mm)
Radial Travel	.90" (22.8 mm)	1.40" (35.5 mm)

Accessories

- Counterbore Module Kit
- Reversible Drive Housing Kit
- Lathe Stand Kit
- Carrying Case
- Sever Kit

Note To The Customer

Spare Parts and Standard Tool Bits are available from stock. Engineering design services for custom tool bits and special function modifications are available from the factory.

All Tri Tool Technologies and allied equipment products are subject to design improvements and specification changes at any time with no obligation to units already sold.

Warranty (limited): Parts and equipment are warranted against defects in material and workmanship for a period of one (1) year from date of purchase. Full details supplied on request and/or with the tools.

 www.tritool.com

 @tritooltechnologies

 @tritooltech

 @tritooltechnologies



3041 Sunrise Blvd
Rancho Cordova, CA 95742
+916-288-6100
+1-800-345-5015
Fax 916-288-6160

Copyright © Proprietary property of Tri Tool Technologies. No reproduction, use or duplication of the information shown hereon is permitted without the express written consent of Tri Tool Technologies.