

TECHNICAL SPECIFICATION MODEL 603.5SBCM LOW PROFILE CLAMSHELL

The 603.5SBCM Low Profile Clamshell is a split-frame pipe lathe for severing and beveling in-line pipe with a range of 2 1/2" pipe through 4" tube with minimal radial and axial clearances.

Accessories

- Socket Weld Removal Tool Module Kit
 - Auto-Disengage Tripper Module Kit
-

Design and Operating Features

- Easily adjustable precision bearing surfaces preload and stabilize the rotating head to provide long life, low maintenance, stability and precision.
- The Clamshell splits into two halves for mounting on closed loop systems. All parts are secured to the two halves to avoid loss of parts and provide maximum ease of handling.
- The machine is equipped with self-centering collets.
- Dual dovetail tool modules with auto-feed sprockets and adjustable gib provide maximum maintainability, life and operator safety with minimum operator training.
- The auto-feed star sprockets provide .003" (.08mm) of radial feed per revolution for a controlled depth of cut.
- Drive worm, worm gears and bearing surfaces are covered for operator safety.
- Operator controls are away from the rotating headstock for safety.
- Modular design concepts provide quick, easy maintenance and maximum versatility in drive and tooling options.
- Detachable Bayonet-type motor provides maximum handling ease and low axial clearance. A flex drive shaft is also available to bring the motor away from the tool.
- All parts are plated for clean room or glove bag use. Tool contains no lead, no brass or copper.

Specifications

Reference Drawing No. 77-1712

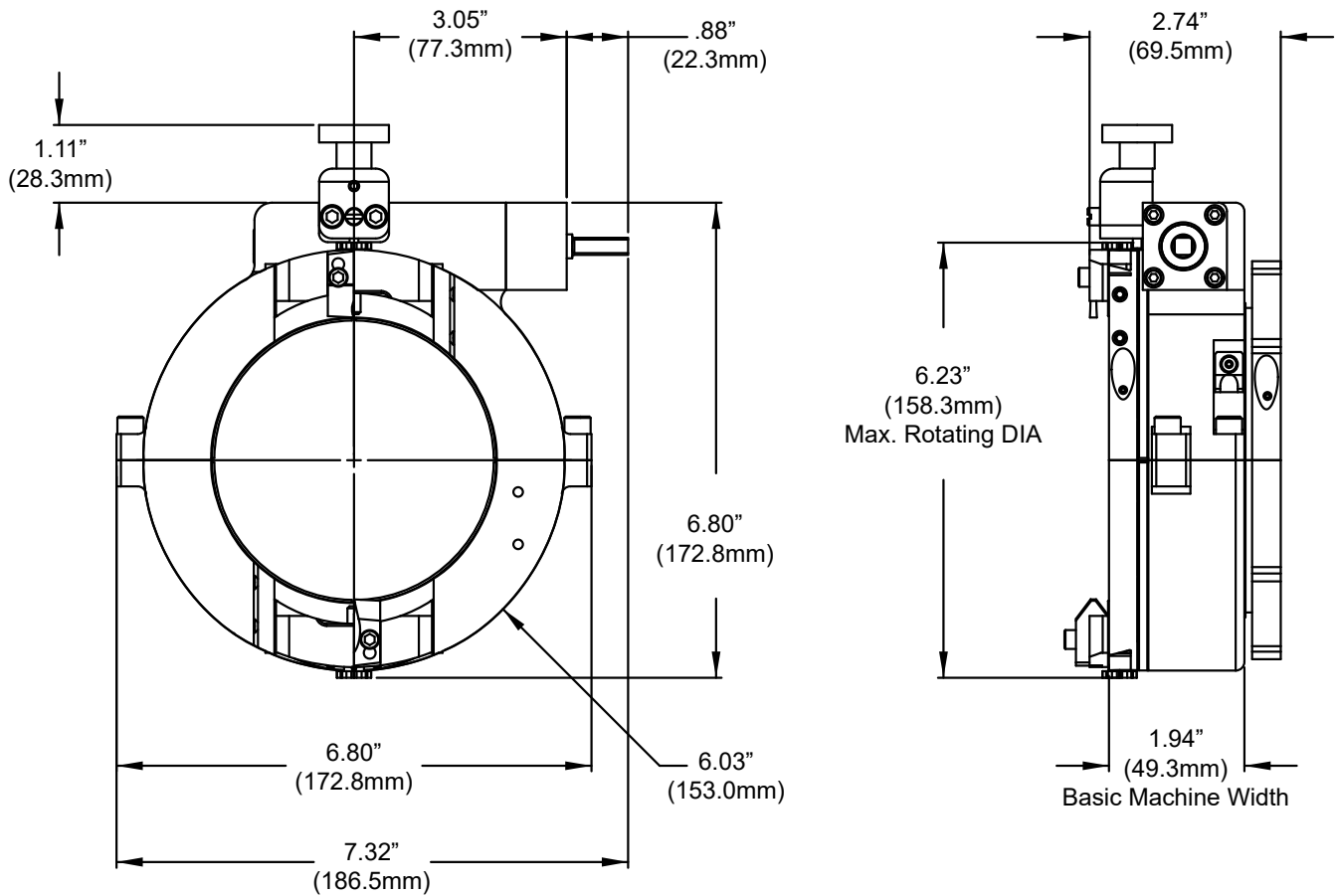

Pipe Cutting Capacities

Cutting Capacities* on 2 1/2" pipe through 4" tube

Severing with standard procedures	.250" wall (6.35 mm)
Severing with special procedures	.358" wall (9.09 mm)
Severing and single beveling	.250" wall (6.35 mm)
Severing and double beveling	.188" wall (4.79 mm)

*Capacity exceeds maximum wall thickness for small pipe sizes)

Material Cutting Capabilities

Materials include, but are not limited to carbon steel, low alloy steel, chrome steel (20% max), chrome/moly alloys (Rc 32 max), austenitic stainless steel, Inconel, copper, aluminum, and copper nickel alloys.

Clearance and Dimensions

Weight

Basic machine	8.7 lbs. (3.95 kg)
Motor	5.4 lbs. (2.43 kg)

Drive Options

Bayonet-type air motor

Air requirements @ 90 PSI	32 CFM
Horsepower	0.7 H.P.
Head speed @ max. H.P.	15 RPM

Clamping

Fixed, self-centering collet sets.

All sizes within the specified size range are available upon request.

Note To The Customer

Spare Parts and Standard Tool Bits are available from stock. Engineering design services for custom tool bits and special function modifications are available from the factory.

All Tri Tool Technologies and allied equipment products are subject to design improvements and specification changes at any time with no obligation to units already sold.

Warranty (limited): Parts and equipment are warranted against defects in material and workmanship for a period of one (1) year from date of purchase. Full details supplied on request and/or with the tools.

 www.tritool.com

 @tritooltechnologies

 @tritooltech

 @tritooltechnologies



3041 Sunrise Blvd
Rancho Cordova, CA 95742
+916-288-6100
+1-800-345-5015
Fax 916-288-6160

Copyright © Proprietary property of Tri Tool Technologies. No reproduction, use or duplication of the information shown hereon is permitted without the express written consent of Tri Tool Technologies.
