

OPERATION MANUAL

92-0579 Rev. 230112
Model 301SP Tube Squaring Machine



ABOUT TRI TOOL TECHNOLOGIES

A thick red horizontal line that starts from the left edge of the page, extends to the right, and then turns downwards at a 45-degree angle to the left, ending at the left edge of the text area.

At Tri Tool, we are committed to your success through relentless innovation and powerful partnership. We insist on developing tools and equipment that exceed your expectations of performance, precision, safety, and durability. As a full-service engineering firm, we are here to support you every step of the way.

For more information on engineered solutions, products, and trainings, visit tritool.com or contact our engineers at +1(916) 288-6100.

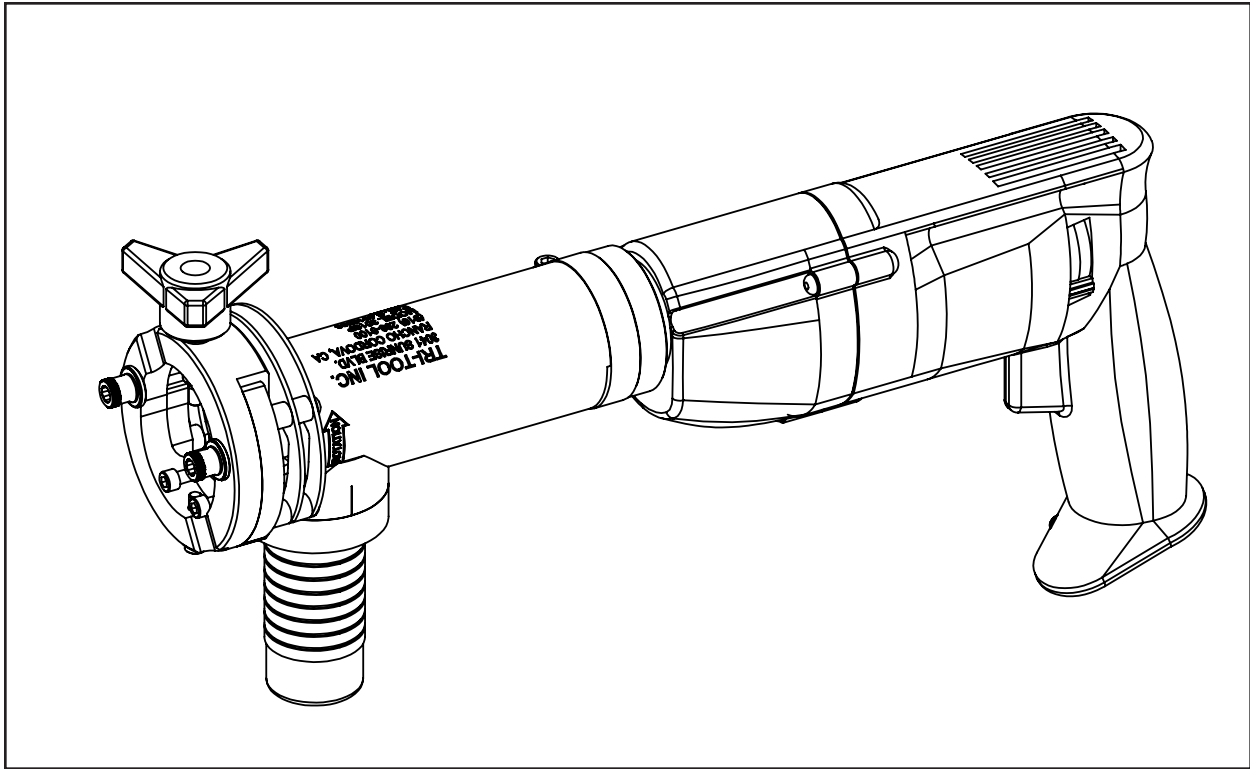

TABLE OF CONTENTS

Tri Tool Inc. Warranty	2
Tool Bit Resharpener Policy	3
About The Manual	4
Safety	6
General Description	8
Specifications	10
Maintenance	11
Operation	12
Chip Guard with Door Installation	18
Cutting Speeds and Feeds	21
Saddle Sets	22
Tool Bits	28
Troubleshooting	30
Accessories	32
Metabo Safety Instructions	33
Illustrated Parts Breakdown	34

TRI TOOL INC. Warranty

LIMITED WARRANTY: All products manufactured by Seller are warranted to be free from defects in materials and workmanship under normal use. The period of this warranty shall be three years from the date of shipment for all products, except for welding and Non-Standard Products which shall be one year from the date of shipment. The Buyer shall bear all shipping, packing and insurance costs and all other costs to and from a designated repair service center. All return goods must be authorized in advance and communicated upon issuance of a Return Material Authorization (RMA) by Seller. The product will be returned to the Seller accompanied by a RMA number and associated paperwork, freight prepaid and billed to the Buyer. This warranty is not transferable and will not apply to tool bits or other consumables, or to any Goods to have been (i) mishandled, misused, abused or damaged by Buyer or any third party; (ii) altered without the express permission in writing by Seller, (iii) repaired by a party other than Seller without Seller's prior written approval; or (iv) improperly stored, installed, operated, or maintained in a manner inconsistent with Seller's instructions. This warranty does not apply to defects attributed to (i) normal wear and tear or (ii) failure to comply with Seller's safety warnings.

No warranty for any parts or other supplies provided to seller by buyer, whether or not they are incorporated into goods. Goods supplied by seller which are designed or manufactured by a third party are subject strictly to the third party's warranty for those goods. Seller makes no warranty and disclaims all statutory or implied warranties for these goods, including the implied warranties of merchantability, freedom from patent infringement and fitness for a particular purpose.

Neither this warranty nor any other warranty, expressed or implied, including implied warranties of mechanical ability, fitness for a particular use, or merchantability, shall extend beyond the warranty period. No responsibility is assumed for any incidental or consequential damages. Some states do not allow limitations on how long an implied warranty lasts and some states do not allow the exclusion or limitations incidental or consequential damages, so the above limitation of exclusion does not apply to all Buyers. This warranty gives the Buyer specific legal rights. Other rights vary from state to state.

Warranty Claims and Remedies

Buyer must promptly notify Seller in writing during the applicable warranty period, of any defective Goods covered by Seller's warranties under the Limited Warranty section herein, and no later than fifteen (15) calendar days after discovery of the defect. Seller has no obligation to honor any warranty claim made after the expiration of the warranty period. However, despite the expiration of the warranty period, Seller, at its reasonable discretion, may accept warranty claims submitted up to fifteen (15) calendar days after the expiration of the warranty period provided that Buyer provides Seller with credible and persuasive documentary evidence that the defect was discovered during the warranty period. No warranty claims submitted after this fifteen (15) day calendar period will be considered by Seller.

Buyer's notice of a defective Goods must identify the specific Goods affected, and the nature of the defect. It is required when returning the defective Goods, that it is suitably packed, fully insured, and transportation and insurance prepaid in accordance with instructions issued by Seller. Seller, at its sole option, will either repair or replace any Goods authorized for return to Seller. Such repair, replacement, or credit shall be Buyer's sole remedy for defective Goods. Buyer must promptly provide Seller with all information requested regarding the identified defect.

If the defect claimed by Buyer cannot be reproduced or otherwise verified by Seller, the Goods will be returned to Buyer unmodified at Buyer's expense.

The warranty period for repaired or replaced Goods shall be (i) ninety (90) days or (ii) the unexpired portion of the original warranty period. Under no circumstances is Seller liable for recall, retrieval, removal, dismantling, re-installation, redeployment, or re-commissioning of any defective Goods or any costs associated therewith.

Tool Bit Resharpener Policy

Buyer is required to check all tool bits prior to returning and ensure they are packaged well for shipment. The price structure is available from the Seller's sales coordinator. Seller cannot resharpen badly gouged, chipped, or broken tool bits. Seller will return tool bits that are not suitable for resharpening with the tool bits that were resharpened upon Buyer's request. Buyer is responsible for all shipping charges to and from Seller.



1. ABOUT THE MANUAL

ORIGINAL INSTRUCTIONS

Copyright

©Copyright Tri Tool Inc. Proprietary property of Tri Tool Inc. No reproduction, use, or duplication of the information shown hereon is permitted without the express written consent of Tri Tool Inc.

Disclaimer

The instructions and descriptions in this manual were accurate when the manual was written. However, the information in the manual is subject to change without notice. Check for updated information before you start any job. The Tri Tool Inc. web site has the most current information.

Do not operate or work on this equipment unless you have read and understood the instructions in this Manual. Failure to follow the instructions or follow the safety instructions could result in serious injury or death. This manual describes conditions and hazards that are common and anticipated during equipment operation. No manual can address all conditions which may occur.

Safety Symbols

The manual may contain one or more safety symbols. These symbols and the associated text warn you of potentially hazardous conditions. Examples of the safety symbols and the associated text follow:



DANGER

DANGER: Indicates a hazardous situation that, if not avoided, will result in serious injury or death.



WARNING

WARNING: Indicates a hazardous situation that, if not avoided, could result in serious injury or death.



CAUTION

CAUTION: Indicates a hazardous situation that, if not avoided, could result in minor or moderate injury, or cause property damage.



GLASSES

SAFETY GLASSES: Indicates a hazardous situation that requires the use of safety glasses.



HOT SURFACE

HOT SURFACE: Indicates a hazardous situation that hot surfaces may be present.



GLOVES

GLOVES: Indicates a hazardous situation that requires glasses.



SHOCK HAZARD

ARC FLASH & SHOCK HAZARD: High voltage. Entry by authorized personnel only. Appropriate PPE and tools required when working on this equipment.



READ MANUAL

READ MANUAL: Read manual before use, refer to manual for Tri Tool machine being used.



DISCONNECT FROM POWER

DISCONNECT FROM POWER: Disconnect main plug from electrical outlet before performing all maintenance.

2. SAFETY PRECAUTIONS

In General

Use standard safety equipment such as: hard hats, safety shoes, safety harnesses, protective clothes, and other safety devices when appropriate.

Operate this tool only in accordance with specific operating instructions.



WARNING: Do not override the dead-man switch on the power unit. Locking down, obstructing, or in any way defeating the dead-man switch on the power drive unit may result in serious injury.

Personal Protective Equipment

Use standard safety equipment such as: hard hats, safety shoes, safety harnesses, protective clothes, and other safety devices when appropriate.

Wear safety glasses.

Do not wear loose clothing or jewelry.

Wear nonskid footwear.

Put long hair in a cap or a net to make sure hair does not get tangled in equipment.

Personnel

Only personnel who are trained or are being trained may operate the equipment.

Keep the operation manual available where the equipment is used.

The operator must read the operation manual before using the equipment.

The equipment must be operated in accordance with the manual information.

The operator must follow the safety precautions in this manual and good engineering practices to reduce the risk of injury.

Before using the equipment, the operator must ensure that all safety messages on the equipment are legible.

Work Area

Keep the work area clean.

Keep the area well lit.

Keep items such as electrical cords, cables, rags, rigging straps, away from rotating equipment.

Do not use power-cutting tools in the presence of flammable liquids and gases.

Do not let visitors or untrained personnel near tools that are in use.

Ensure all observers wear eye protection.

Keep proper footing at all times.

Area Equipment

Secure the pipe with clamps, vises, chains or straps.

Ensure that both sides of the pipe at the cut site is fully supported so that the pipe will not move after the cut is completed. Long lengths of pipe may be under load and the separation of the pipe can release pressure. This pressure can cause both sides of the pipe to move.

Tool Care

Keep tools in good operating condition. Sharp tool bits perform better and are safer than dull tool bits.

Do not use damaged tools. Always check your tools for damage especially if a tool has malfunctioned, been dropped or hit, check it for damage.

Before you start operating the equipment, do no-load tests and feed function checks.

Tool Use

Use the right tool and tool bit for the job. Contact Tri Tool to help with your application.

Keep the tool bits fully engaged in the tool bit holders. Loose bits are sharp and can cause cuts or punctures.

Disconnect power supply during setup and maintenance. Use all 'Stop' or Shut off' features available when changing or adjusting tool bits, maintaining the tool, or when the tool is not in use.

Remove adjusting keys and wrenches before applying power to the equipment. Check the tool before turning it on to make sure that all keys and wrenches have been removed.

Do not force tools. Tools and tool bits function better and safer when used at the recommended speeds.

Do not reach into rotating equipment.

Do not reach into the rotating head stock to remove chips, to make adjustments, or to check the surface finish.

Handle chips with care. Chips have very sharp edges and are hot. Do not try to pull chips apart with bare hands.

Store tools properly. Disconnect tools from the power source, remove the tool bits, and store in a safe place.

3. GENERAL DESCRIPTION

The Model 301SP Tube Squaring Machine is a lightweight, portable machine designed for facing and squaring .125 to 1.050 (3.2 mm to 26.7 mm) outside diameter tubing with an ability to handle up to 1/8 (3 mm) thick wall.

Use one of the following with the Model 301SP:

- Integral, variable speed 110 VAC Electric Motor
- Integral, variable speed 220 VAC Electric Motor
- Air Motor
- Battery powered Electric Motor.

Precision inside diameter Saddles hold the tubing round to accurately square and face the tubing with a minimum burr.

The Machine accepts its own torque through the Saddle Clamping system.

The Cutting Head accepts Squaring Tool Bits.

All required tools for operation of the Model 301SP are supplied.

MODEL 301SP CONFIGURATIONS

Model No.	P/N	Configuration
301SP-E110	01-1293	Tube Squaring Machine 110VAC Electric Motor (Metabo)
301SP-E110	01-1297	Tube Squaring Machine 110VAC Electric Motor (Metabo) with Bench Stand
301SP-E220	01-1294	Tube Squaring Machine 220VAC Electric Motor (Bosch)
301SP-E220	01-1298	Tube Squaring Machine 220VAC Electric Motor (Bosch) with Bench Stand
301SP-A	01-1295	Tube Squaring Machine Air Motor
301SP-A	01-1299	Tube Squaring Machine Air Motor with Bench Stand
301SP-B	01-1326	Tube Squaring Machine Electric Motor, Battery Powered, 18V (110V Charger)
301SP-B	01-1353	Tube Squaring Machine Electric Motor, Battery Powered, 18V (220V Charger)

4. SPECIFICATIONS

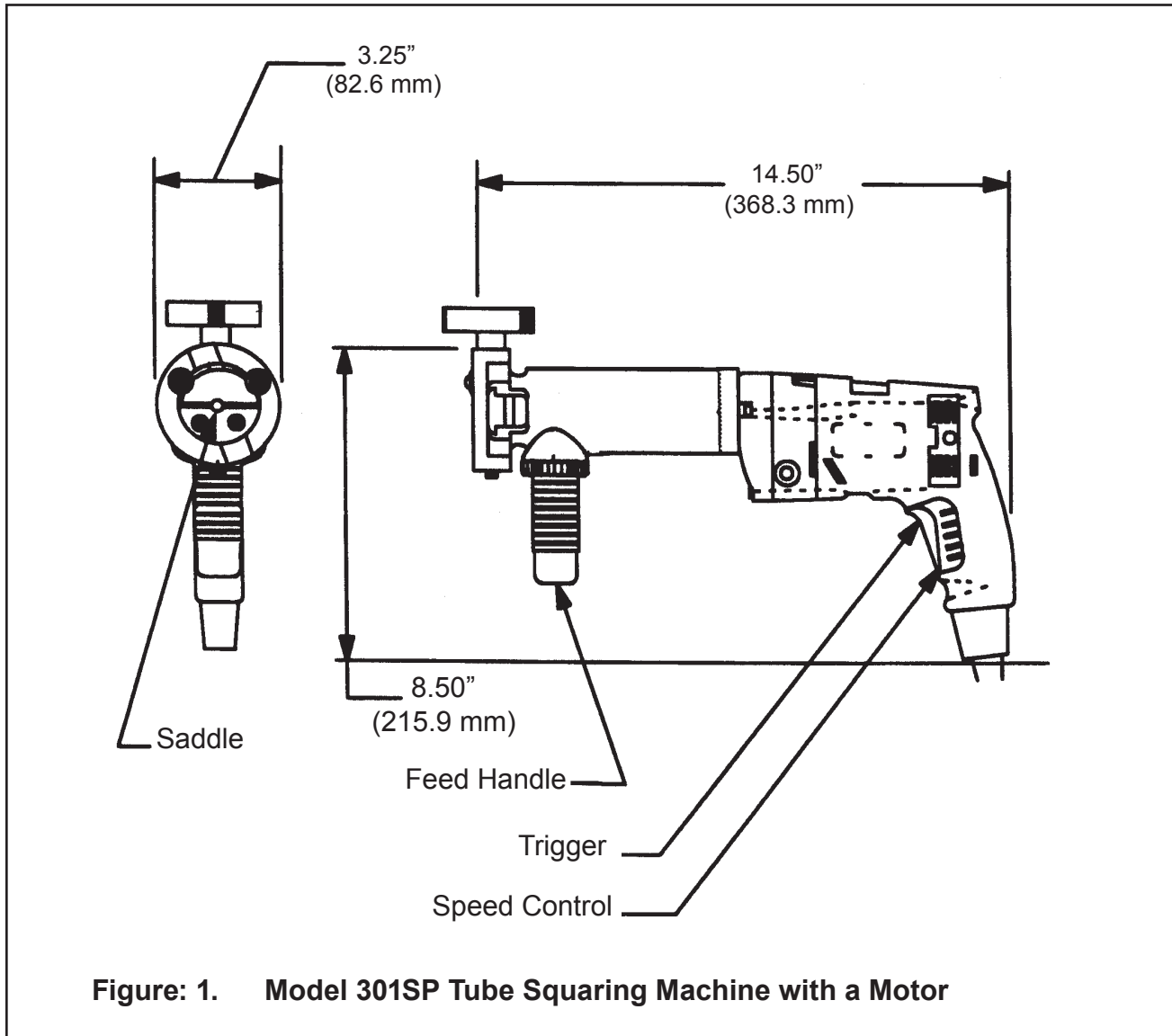

Weight with a Motor (Approx.): 8.5 lbs. (3.9 kg)
 (varies with Saddle size and type of Motor).

POWER REQUIREMENTS

Model No.	P/N
301SP 110	110 VAC +/- 10%, 25 to 60 Hz
301SP 220	220 VAC +/- 10%, 25 to 60 Hz
Model 301SP-A	22 cfm at 90 psi (10 L/s at 621 kPa)

5. MAINTENANCE

ALL MODELS

- Clean all components, refer to Fig 2.
- Coat all components with a light film of oil before use. Use a clean, non-detergent oil, preferably SAE 10 (90SSU) or lighter.
- If the Model 301SP is operated in the vertical position (Cutting Head up), turn it upside down and remove the chips and all debris after each cut. The tool life may be severely shortened, if chips and/or other debris are not removed.
- Disassembly of the Model 301SP will void the warranty, except when performed by TRI TOOL Inc. designated repair technician.

301SP with an Air Motor

Include an adequate filter, regulator and lubricator (FRL), for the air supply. The Air Motor warranty is void if damage occurs from contaminated air or lack of lubrication.

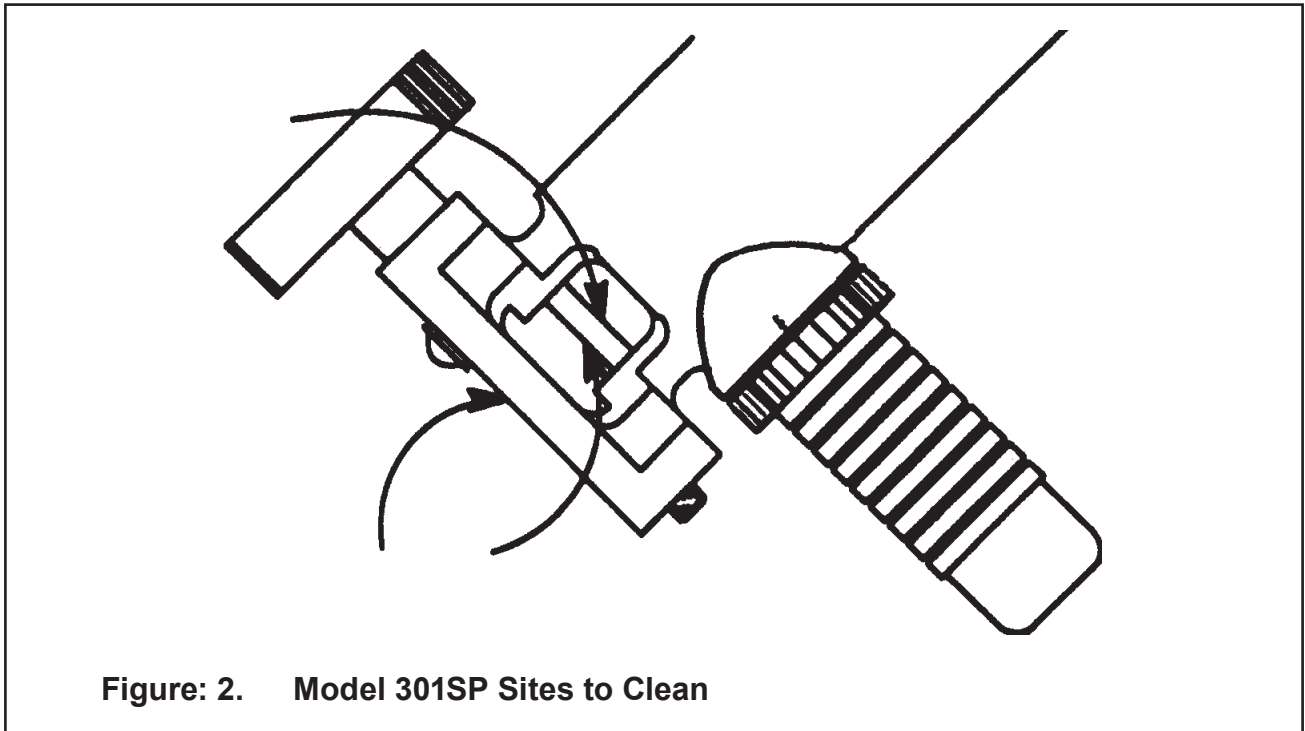

Figure: 2. Model 301SP Sites to Clean

6. OPERATION



DANGER

DANGER: Do not override the deadman switch on the power unit. Locking down, obstructing, or in any way defeating the deadman switch may result in serious injury.

6.1 Select and Install a Tool Bit

The use of dull tool bits or tool bits not manufactured by TRI TOOL Inc. may result in poor performance and may constitute abuse of this machine and therefore void the TRI TOOL Inc. factory warranty.

General guidelines for selecting a tool bit.

Determine the tubing material, tubing size, and how critical is it to have a near burr free end.

- **CARBON STEEL** - use a standard entrance angle tool bit. These tool bits also function well with some stainless steel applications where a near burr free end is not a critical requirement.
- **MOST STAINLESS STEEL** - use a high entrance angle tool bit for most stainless steels. Generally this is the most suitable edge geometry for about 90% of all the stainless steel tubing applications.
- **SOFT STAINLESS STEEL**- An extra hook angle tool bit is recommended for soft stainless steel. These stainless steels include materials like 316L, which have been bright hydrogen annealed, vacuum annealed or annealed and Electro-polished. Electropolished stainless steel has a micro-thin surface, which is high in Cr and Ni, which makes it very soft, but tough and difficult to cut without a burr.
- **EXOTIC ALLOYS** - Use the M-42 tool bits when the high heat resistance is required to avoid burning the cutting edge of the tool bit. M-42 can improve the life expectancy of the tool bit under some conditions on stainless steel. M-42 tool bits are more brittle than the standard M-2 tool bits, therefore there is a much greater risk of damaging the M-42 tool bit when installing the tubing in the Tube Squaring Machine. Loss of tool bits from damaged edges may not offset the improved cutting life that those tool bits promised. Some of the exotic alloys may require tool bits with both the extra hook angle as well as the M-42 tool steel for heat resistance.

6.2 Install Tool Bit



WARNING

WARNING: Check that the Model 301SP is disconnected from the power source before you install a tool bit.

1. Insert the tool bit into the slot in the Cutting Head, refer to the first part of Fig 3. Do not install the tool bit backwards.
2. Tighten the set screws to secure the tool bit to the Cutting Head.
 - The cutting edge of the tool bit must be located on the radial centerline.
 - This position is used for .50" (12.7 mm) and smaller diameter tubing. Virtually no burr is left on standard tubing. Use slow cutting speeds with Electro-polished to minimize the ID burr.
 - The tool bit may be reversed, refer second part of Fig 3. Use the reversed position for tubing with an ID greater than .50" (12.7 mm). The extreme shear cutting action will virtually eliminate the burr on the ID.
 - Minimum burr may be obtained with a slow RPM and a slow feed, which cuts a continuous chip.

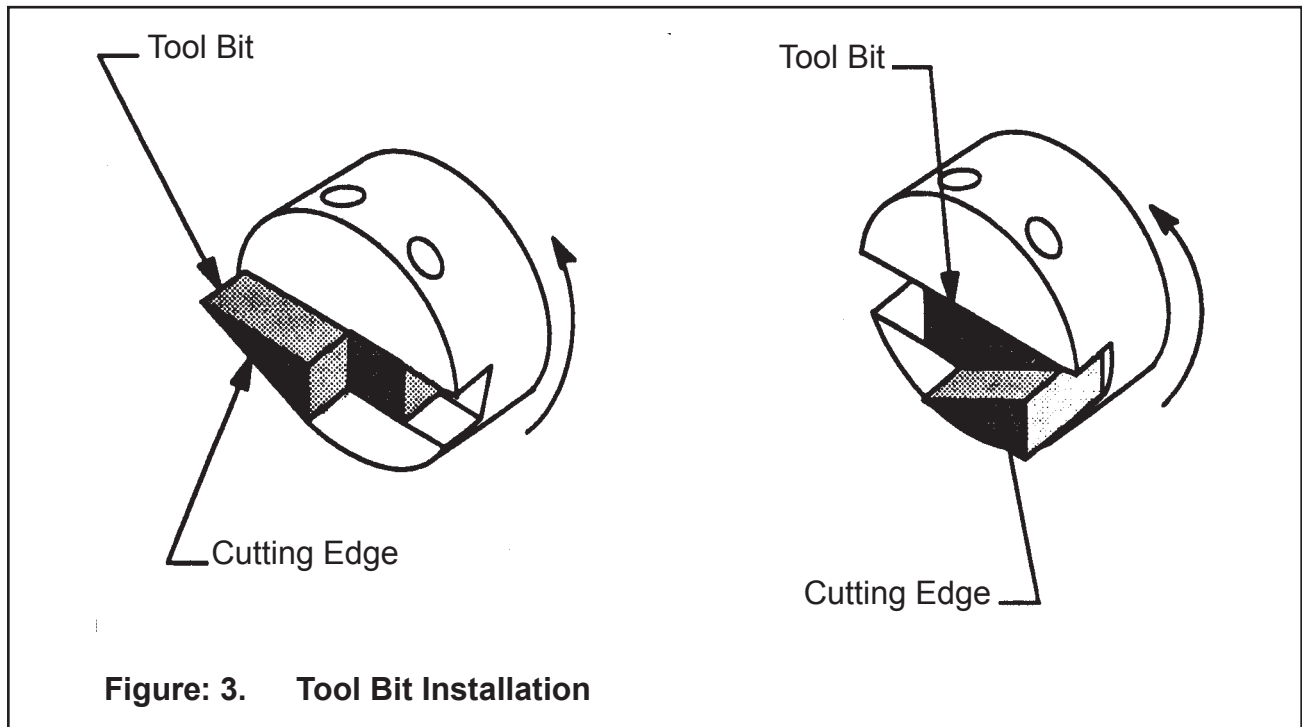

6.3 Select and Install a Saddle

1. Select a Saddle, refer to Section 8, Saddle Sets. The size of the Saddle is determined by the outside diameter of the tube or pipe to be squared. Do not drop the Saddle. Always place a hand under the Saddle when installing or removing it from the Model 301SP.
2. Place the first Saddle half with the two clearance holes in the front of the Housing.
3. Thread in the two Cap Screws to hold the Saddle half into the front of the Housing.

4. Thread the third Cap Screw into the side of the Housing and into the Saddle half.
5. Tighten all three Cap Screws to retain the Saddle half in the front of the Housing.

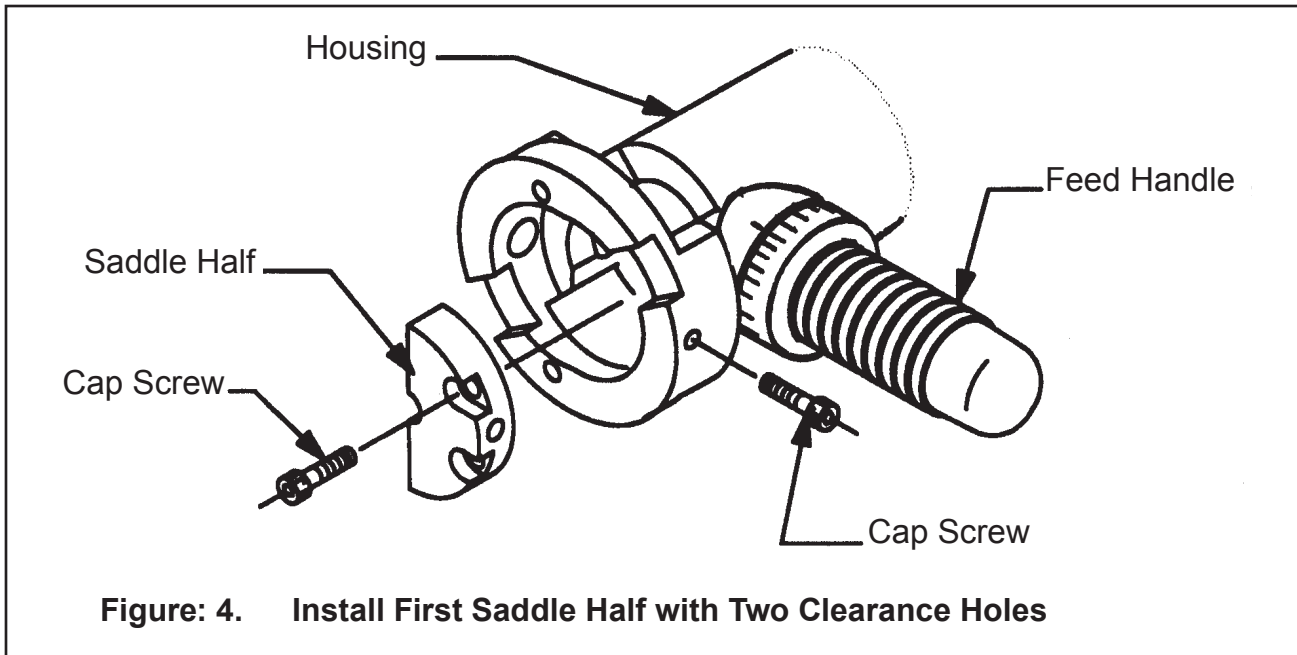

6. Place the second Saddle half in the Housing.

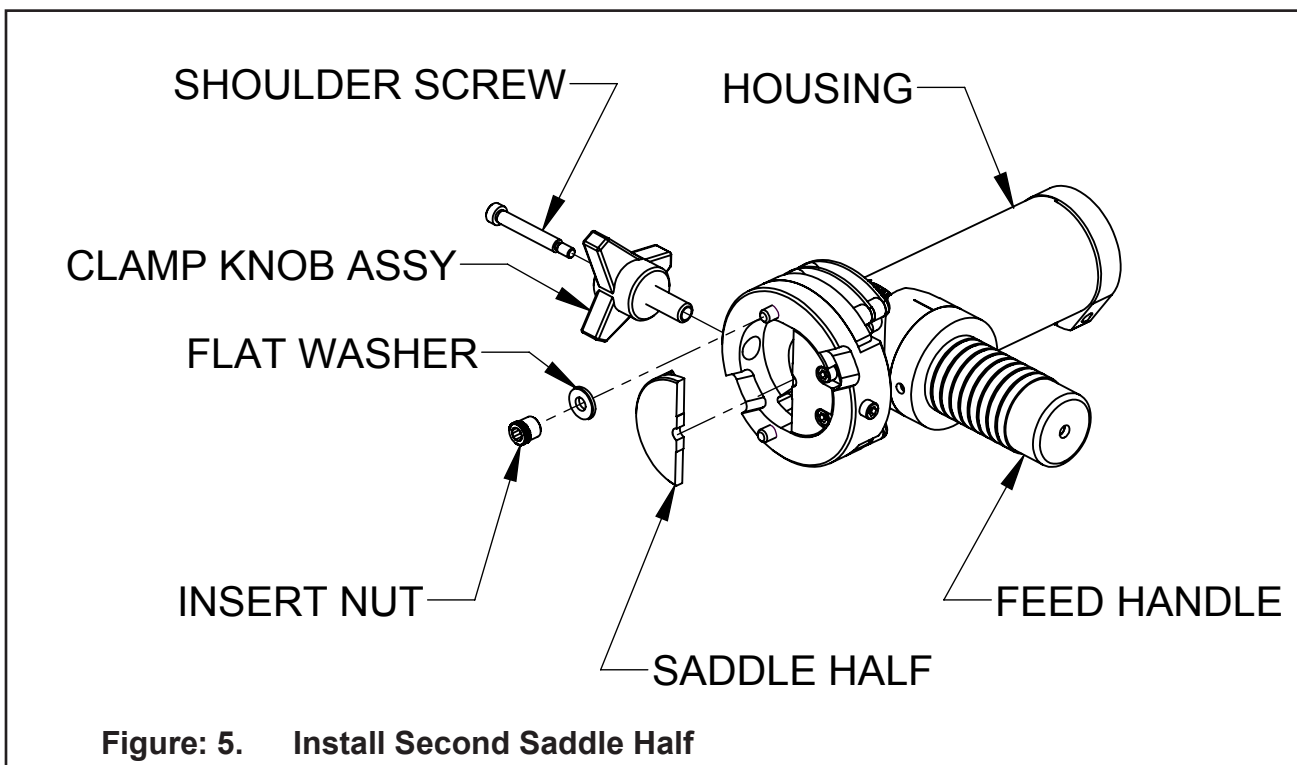

7. Run the Clamp Knob Assy in until it lightly presses the second Saddle half against the first Saddle half.
8. Thread the Shoulder Screw in through the Clamp Knob Assy into the upper half Saddle.
9. Retract the second Saddle half by turning the clamp Knob Assy.
10. Install the two Insert Nuts with the two Flat Washers into the front of the Housing.
11. Insert the tubing to be worked on into the front of the Model 301SP.
12. Move the tube or pipe approximately 1/16" (1.6 mm) from the tool bit.



CAUTION: Do not let the tool bit touch the tube or pipe. This will damage the tool bit or the Tube Squaring Machine when power is applied.

13. Tighten the Clamp Knob Assy to tighten the tube in the Saddle.
14. Connect the Model 301SP to the power source and pull the Trigger to start rotation of the Cutting Head.

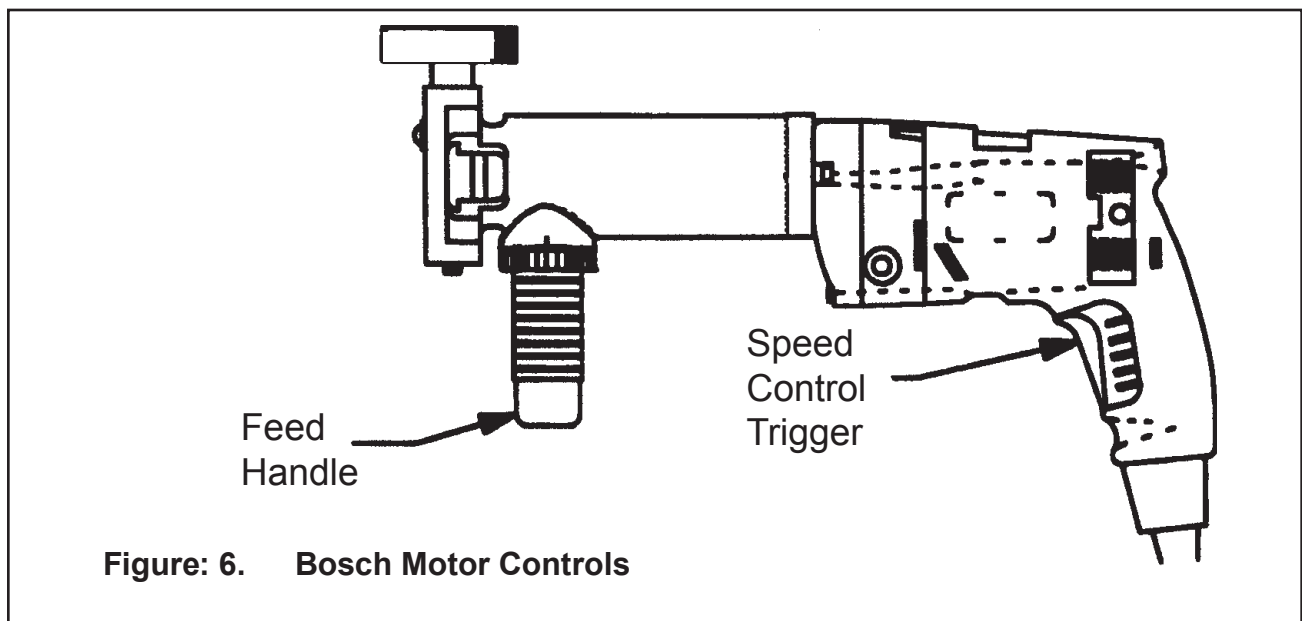
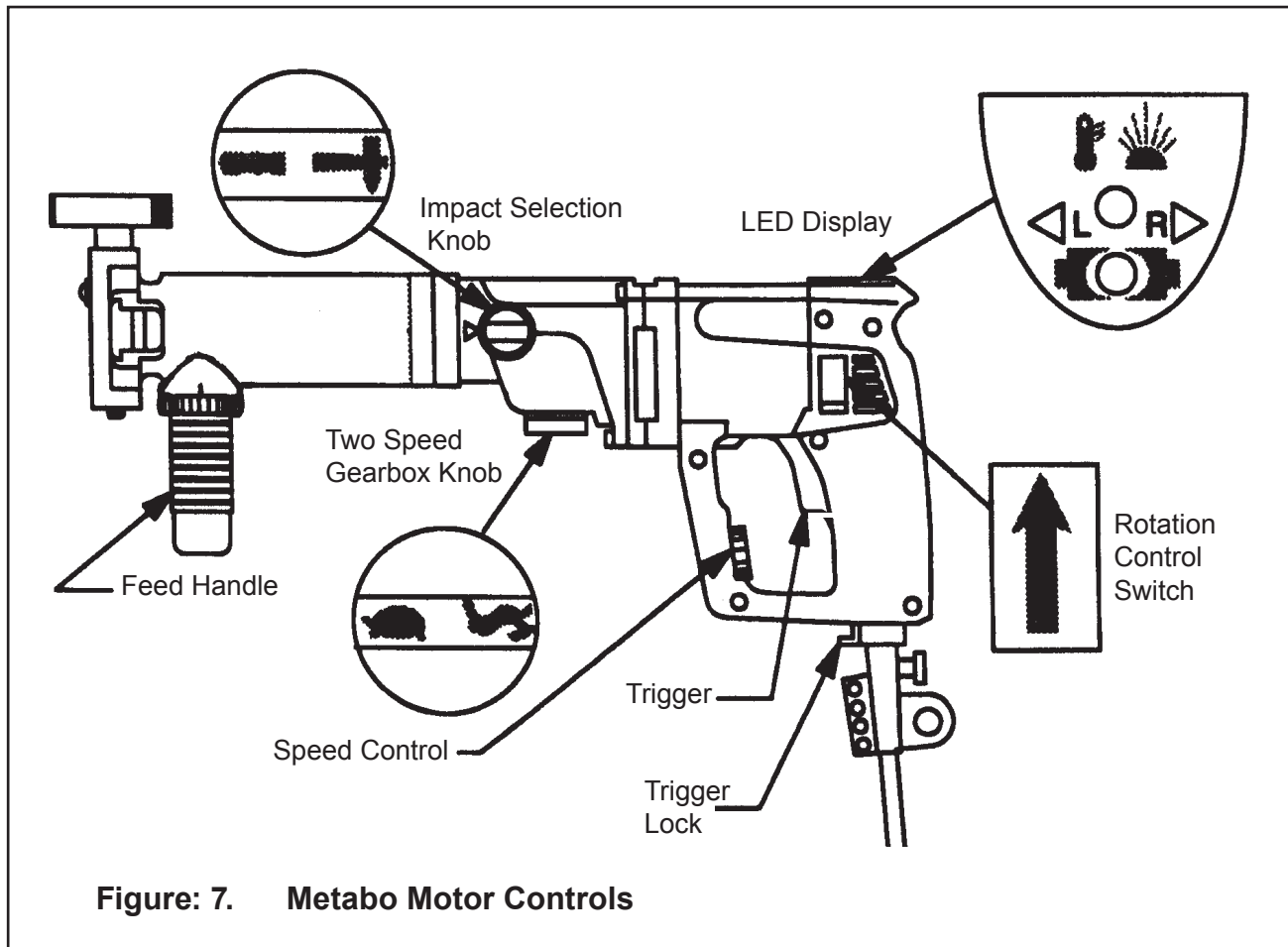

Figure: 6. Bosch Motor Controls

15. If the Machine has a Metabo Motor, use the Speed Control in the Trigger Guard to adjust the cutting speed.



16. For Metabo Motor only
 - The Two Speed Gearbox Knob should be in the position in Fig 7. If the Knob does not snap into the desired position, turn the chuck by hand slightly until the knob snaps into place.
 - The Impact Knob should be in the position shown.
 - The Rotation Control Switch should be in the position shown. The 'R' LED on the LED Display should be lit.
17. Use the Feed Handle to feed the Shaft with the tool bit into the work
18. In order to obtain a minimum burr tube end, avoid heat build up. When either the tube or the tool bit get hot, the tube material starts to flow or push away from the tool bit edge in the form of a burr, instead of being cut cleanly with a minimum burr. Avoid the conditions which generate excessive heat by keeping the RPMs low. Excessive cutting speed will generate unwanted heat.
19. Keep the chip curling loose by avoiding an excessive depth of cut. A dull tool bit will not do the job right, so be sure that there is a sharp tool bit mounted in the Machine.

20. Rotate the Feed Handle clockwise to bring the Cutting Head and tube closer together. The actual machining operation will begin when the tool bit contacts the tube or pipe.
21. If the tube end is not square to the tube axis, the tool bit will contact only a small segment of the tube during each revolution. To avoid tool bit damage, the feed rate should be very slow until the tool bit is contacting the tube continually during at least one revolution.
22. Adjust cutting RPM with the Speed Control Trigger is just above the required cutting speed as the tool bit enters the cut. The tool will slow down slightly as the cutting load increases, apply additional power to hold the cutting speed.
23. Observe the chip as the Machine is cutting.
 - The ideal chip will come off in a loose pig tail spiral.
 - A chip that is coming off in a tight straight spiral normally indicates that the feed is too heavy.
 - A straight or slightly curled chip normally indicates that the feed is too light.
24. Back off the feed as required to break the chips and let them fall away.
25. If a significant amount of stock must be removed, occasionally back off out of the cut and let the tool bit spin free in the air to cool.
26. Continue rotating the Feed Handle clockwise until the end of the pipe is completely machined.
27. Be careful not to let the tool bit cut into the Saddle or the Saddle Adapter.
28. Discontinue feed and allow the Cutting Head to rotate one time for stainless steel and up to three times for other materials to improve the finish of the prep surface.
29. Never let a tool bit 'rub' the surface of a stainless steel tube without cutting. This will work harden the material. So it will be difficult for the tool bit to get under the material to finish the cut. This will also cause excessive tool bit wear.
30. For precision depth of cutting, engage the tool bit into the end of the tube and use the indicator sleeve located on the Feed Handle to check the depth of the cut. The graduations are in .005" increments on one half of the sleeve and .13 mm increments on the other half.
31. Rotate the Feed Handle counterclockwise to separate the Cutting Head and the tube.
32. Release the Trigger to stop the Cutting Head rotation,.
33. Continue to rotate the Feed Handle counterclockwise until the Cutting Head clears the tube or pipe by at least 1/8" (3.2 mm) or more.
34. Loosen the Clamp Knob Assy to release the tube or pipe.

7. CHIP GUARD WITH DOOR INSTALLATION

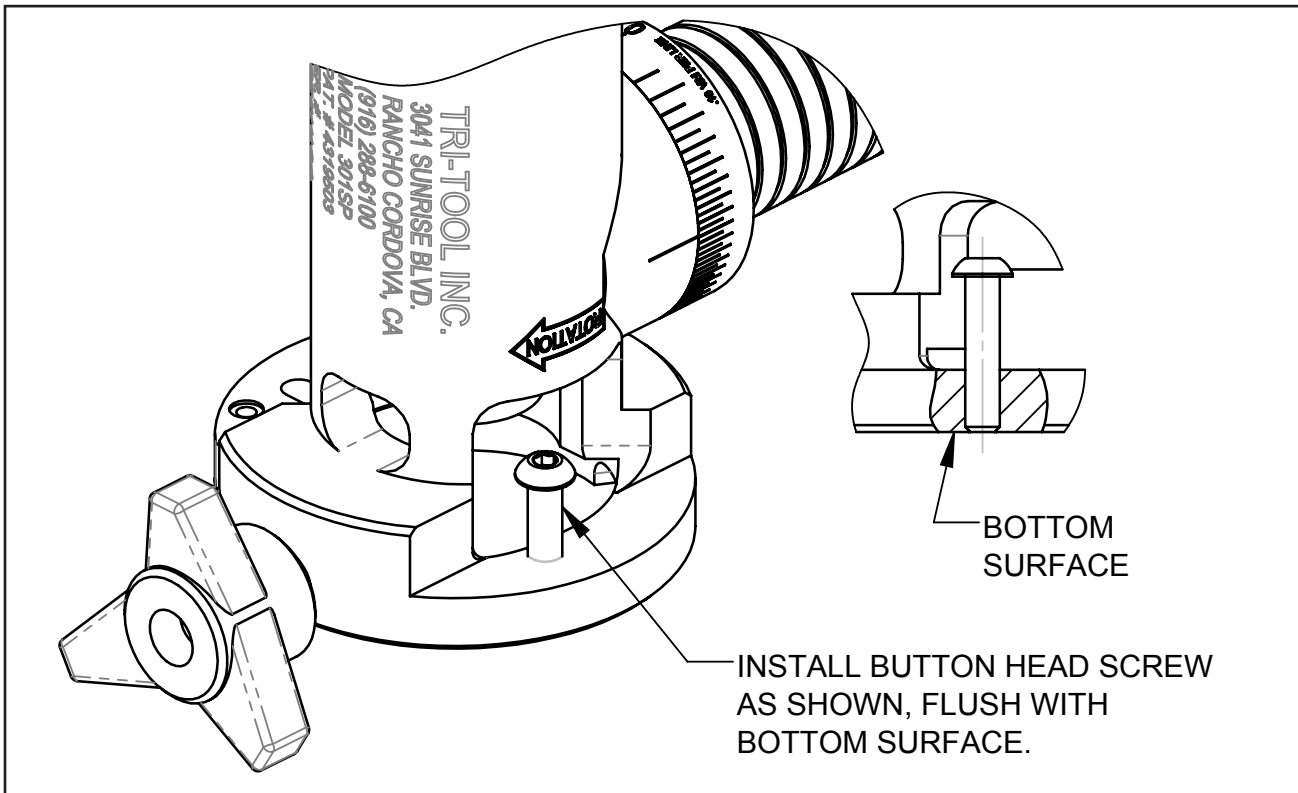
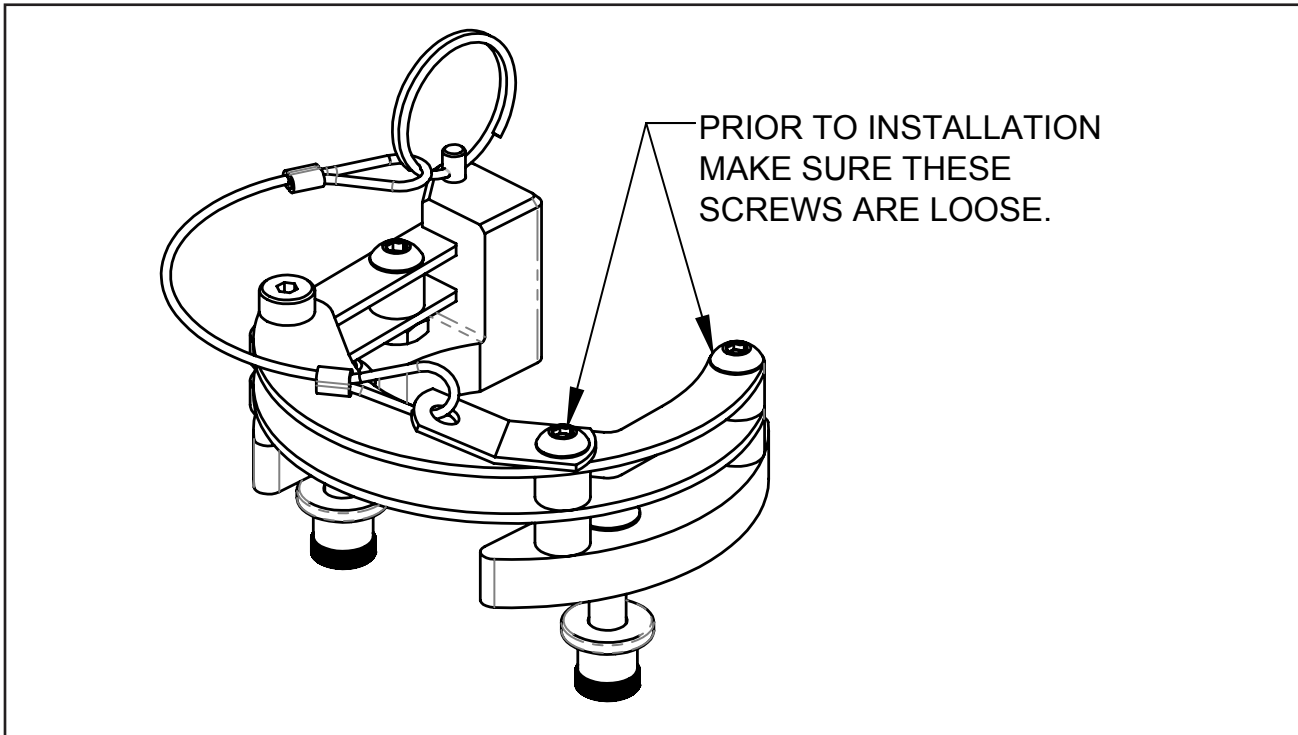

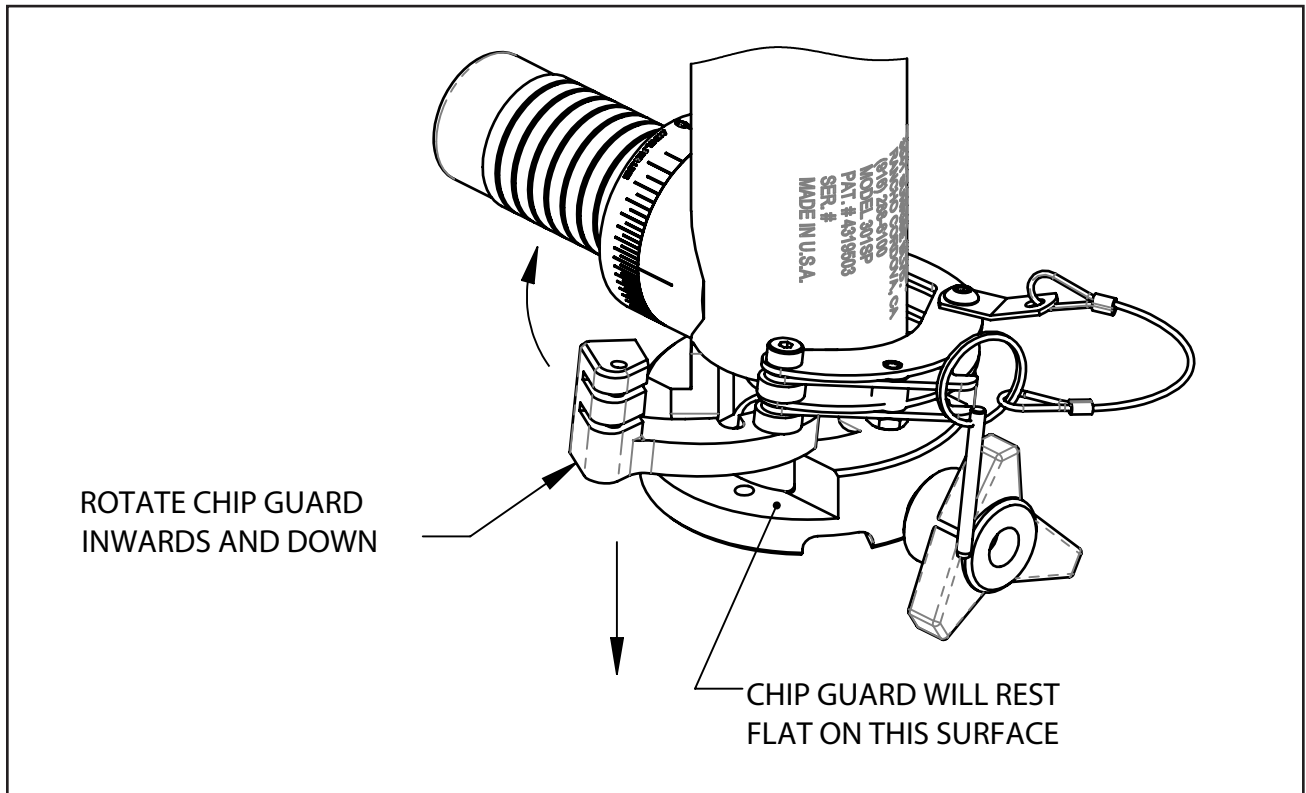
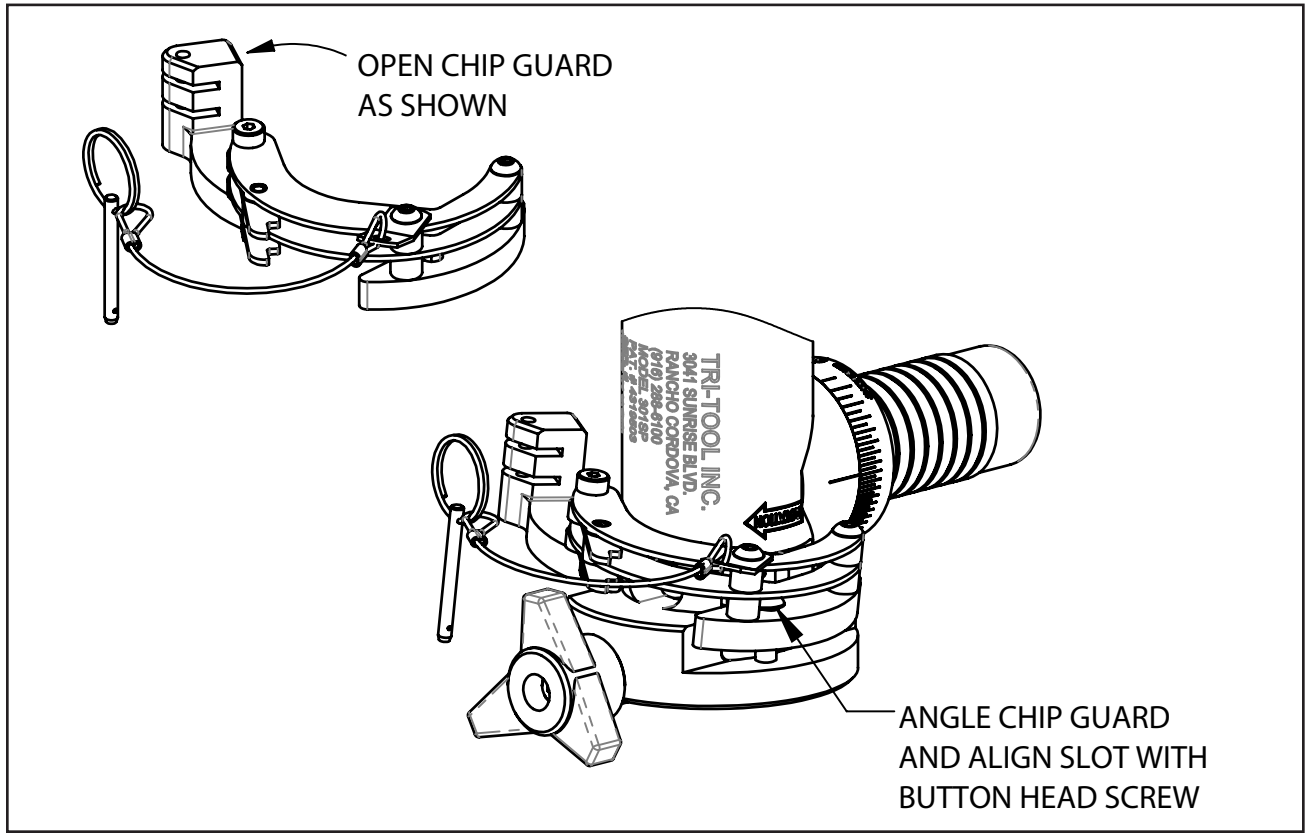

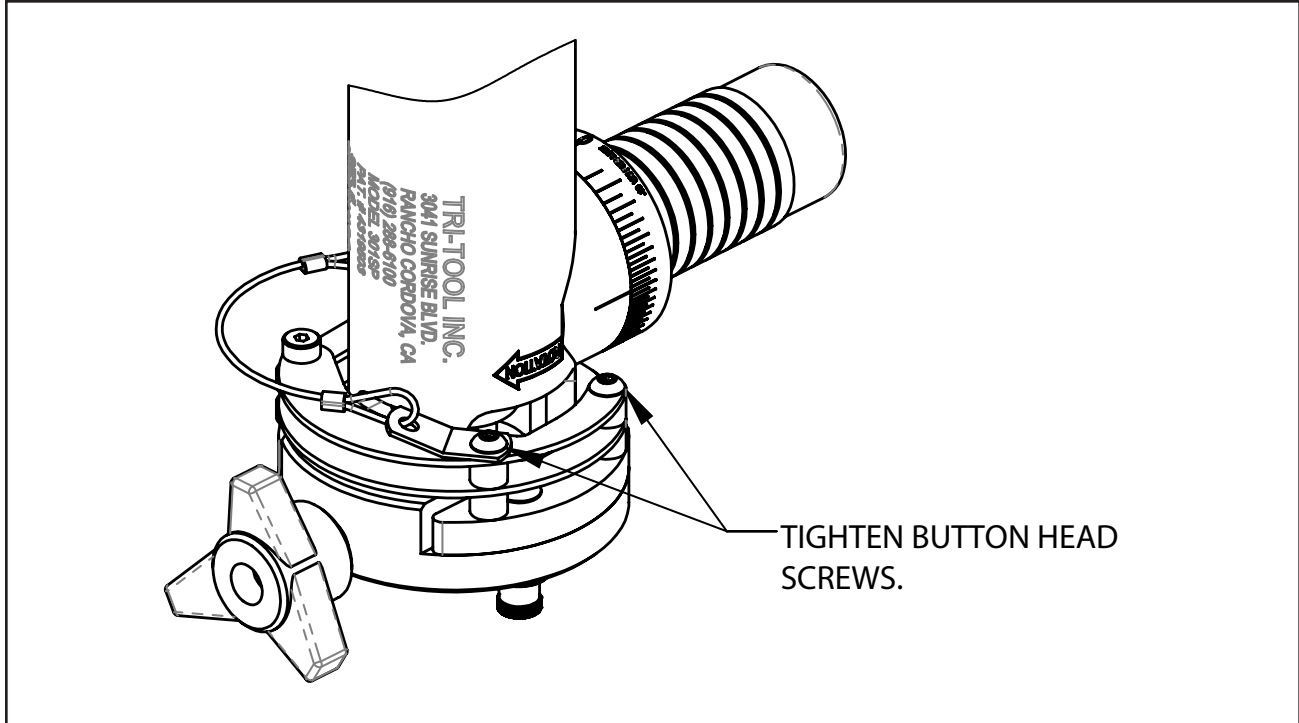
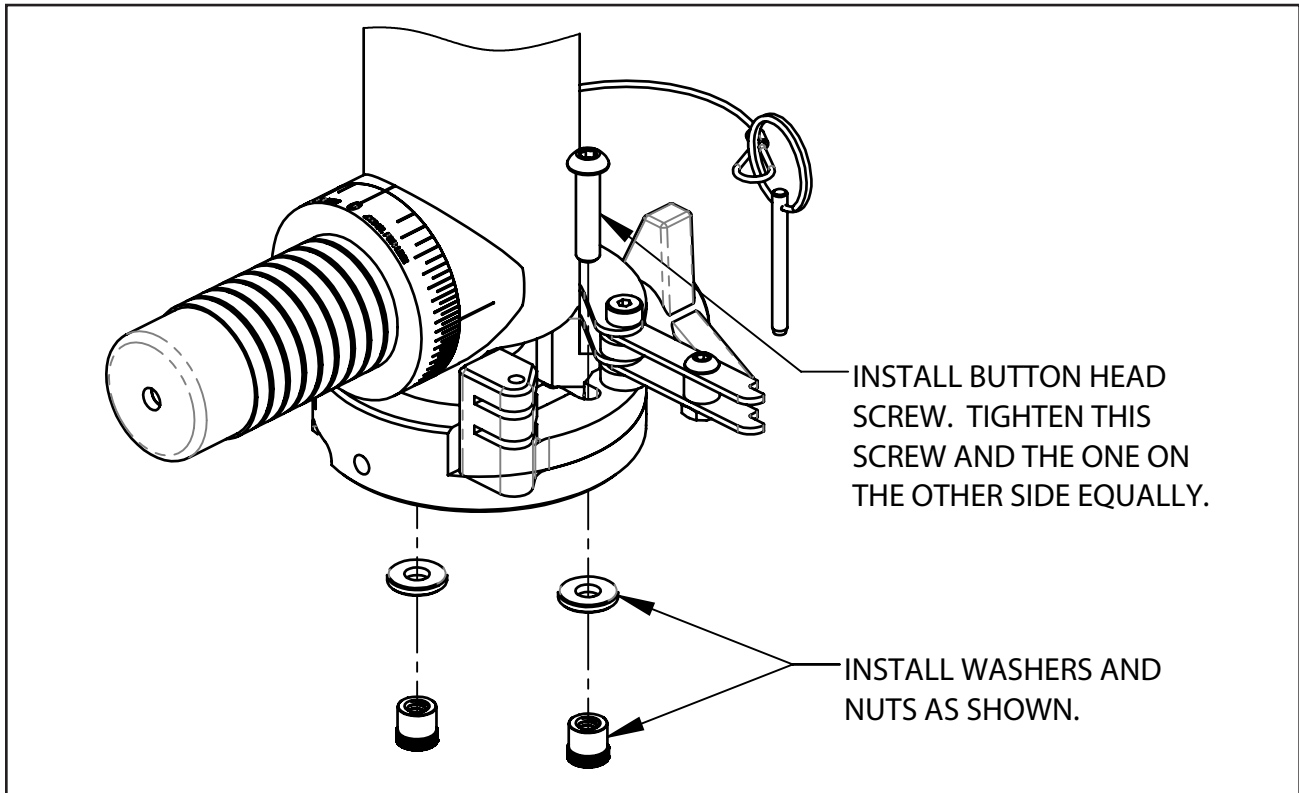

8. CUTTING SPEEDS AND FEEDS

8.1 Cutting Speeds

CUTTING SPEEDS FOR TUBE SQUARING			
Outside Diameter of the Pipe or Tube		RPM Range	Time per Head Revolution
.25"	6.4 mm	30 to 60	1 to 2 seconds
.50"	12.7 mm	20 to 40	1.5 to 3 seconds
.75"	19.1 mm	15 to 30	2 to 4 seconds
1.00"	25.4 mm	15 to 25	2.4 to 4 seconds

8.2 Basic Feed Recommendations

Use very light feed for initial facing or until a continuous cut is established. This is very important for longer tool bit life when cutting through flame cut or out-of-round pipe ends.

Use adequate feed, .003" to .006" (.08 mm to .15 mm) per revolution thereafter, to establish a continuous chip cut. If the feed is too light, only light stringer chips will be removed. If the feed is too heavy, the drive will start to overload and the chip will start to have a rough or torn appearance.

Stainless steel, which work hardens, must be worked with a heavy enough feed to stay under the work hardened surface (.003" to .006" or .08mm to .15mm feed) Never allow the tool bit to burnish the surface.

Reduced feeds and speeds will normally minimize chatter problems.

9. SADDLE SETS

9.1 Standard Saddles Stainless Steel

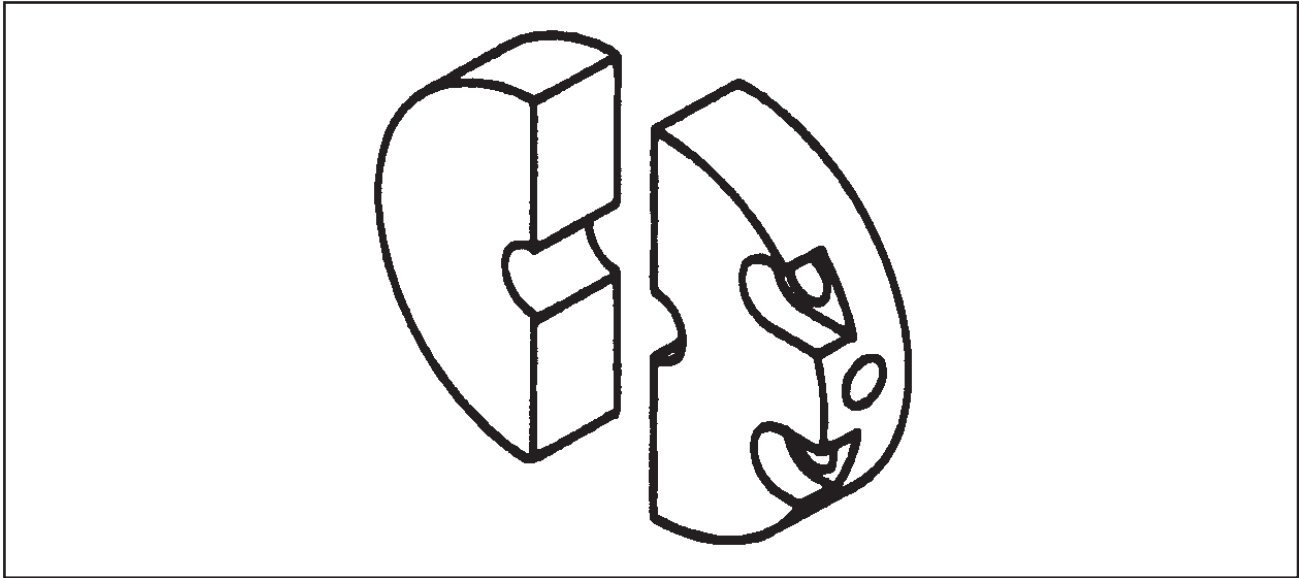

STANDARD SADDLE SETS

Pipe Size	Fraction	Decimal	Metric	Saddle P/N
	1/8"	.125"	3.18 mm	67-3635
	5/32"	.156"	3.96 mm	67-3636
		.158"	4.00 mm	67-3637
	3/16"	.188"	4.78 mm	67-3638
		.197"	5.00 mm	67-3701
		.218"	5.54 mm	67-3639
	1/4"	.236"	6.00 mm	67-3702
		.250"	6.35 mm	67-3640
		.276"	7.00 mm	67-3641
	9/32"	.281"	7.14 mm	67-3642
	5/16"	.313"	7.95 mm	67-3643
		.315"	8.00 mm	67-3644
		.344"	8.74 mm	67-3645
	11/32"	.354"	9.00 mm	67-3646
		.359"	9.13 mm	67-3647
		.365"	9.27 mm	67-3648

STANDARD SADDLE SETS

Pipe Size	Fraction	Decimal	Metric	Saddle P/N
	3/8"	.375"	9.53 mm	67-3649
		.391"	9.92 mm	67-3650
		.394"	10.00 mm	67-3651
		.400"	10.16 mm	67-3652
1/8"	13/32"	.406"	10.31 mm	67-3653
		.413"	10.50 mm	67-3654
		.422"	10.72 mm	67-3655
		.430"	10.92 mm	67-3656
		.433"	11.00 mm	67-3657
	7/16"	.438"	11.13 mm	67-3658
	15/32"	.469"	11.91 mm	67-3659
		.472"	12.00 mm	67-3660
		.489"	12.42 mm	67-3661
		1/2"	.500"	12.70 mm
.512"			13.00 mm	67-3663
17/32"	.531"	13.50 mm	67-3664	
1/4"		.540"	13.72 mm	67-3665
		.543"	13.80 mm	67-3666
		.547"	13.89 mm	67-3667
		.551"	14.00 mm	67-3668
	9/16"	.563"	14.30 mm	67-3669
		.591"	15.00 mm	67-3670
	19/32"	.594"	15.08 mm	67-3671
		.602"	15.29 mm	67-3672
	5/8"	.625"	15.88 mm	67-3673
		.630"	16.00 mm	67-3674
		.641"	16.27 mm	67-3675
	21/32"	.656"	16.66 mm	67-3676
		.669"	17.00 mm	67-3677

STANDARD SADDLE SETS

Pipe Size	Fraction	Decimal	Metric	Saddle P/N
3/8"		.675"	17.15 mm	67-3678
		.677"	17.20 mm	67-3679
		.681"	17.30 mm	67-3680
	11/16"	.688"	17.48 mm	67-3681
		.709"	18.00 mm	67-3682
	23/32"	.718"	18.24 mm	67-3683
	3/4"	.750"	19.05 mm	67-3684
		.781"	19.84 mm	67-3685
	25/32"	.787"	20.00 mm	67-3686
		.790"	20.07 mm	67-3687
1/2"	13/16"	.813"	20.65 mm	67-3688
		.840"	21.34 mm	67-3689
		.844"	21.44 mm	67-3690
		.854"	21.70 mm	67-3691
	27/32"	.859"	21.83 mm	67-3692
		.866"	22.00 mm	67-3693
		.875"	22.23 mm	67-3694
	29/32"	.906"	23.00 mm	67-3695
	15/16"	.938"	23.83 mm	67-3696
	31/32"	.969"	24.61 mm	67-3697
	.984"	25.00 mm	67-3698	
3/4"	1"	1.000"	25.40 mm	67-3699
		1.050"	26.67 mm	67-3700

9.2 Short Perch Saddles Stainless Steel

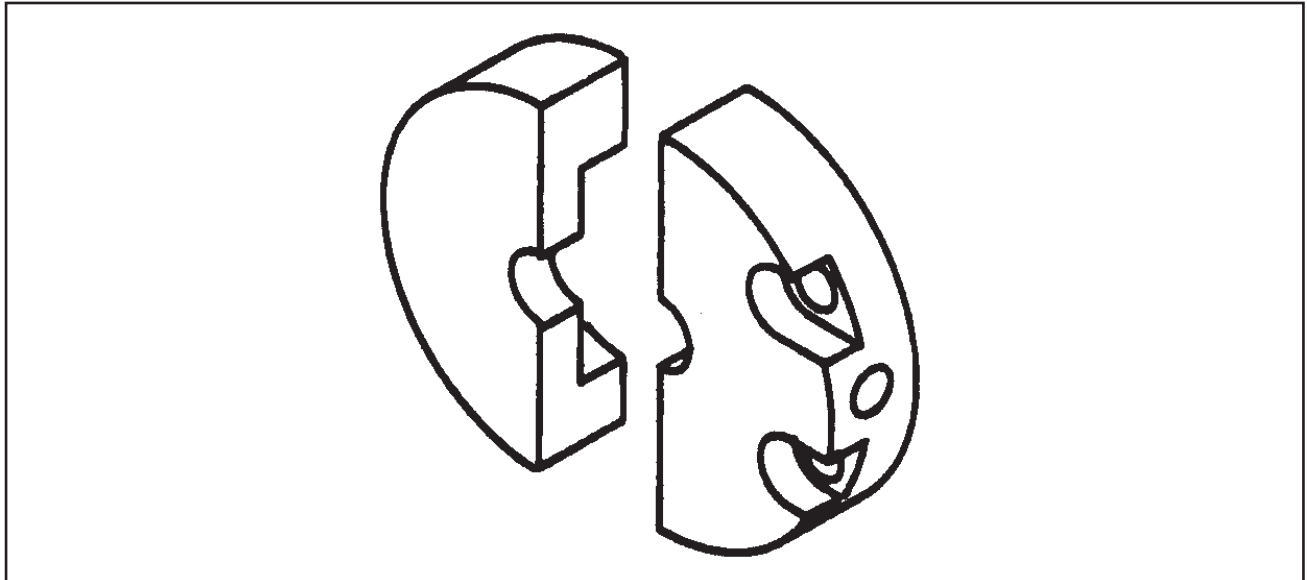

SHORT PERCH SADDLE

Pipe Size	Fraction	Decimal	Metric	Saddle P/N
	1/8"	.125"	3.18 mm	67-3705
	5/32"	.156"	3.96 mm	67-3706
		.158"	4.00 mm	67-3707
	3/16"	.188"	4.78 mm	67-3708
		.197"	5.00 mm	67-3771
		.218"	5.54 mm	67-3709
	1/4"	.236"	6.00 mm	67-3772
		.250"	6.35 mm	67-3710
		.276"	7.00 mm	67-3711
	9/32"	.281"	7.14 mm	67-3712
	5/16"	.313"	7.95 mm	67-3713
		.315"	8.00 mm	67-3714
	11/32"	.344"	8.74 mm	67-3715
		.354"	9.00 mm	67-3716
		.359"	9.13 mm	67-3717
		.365"	9.27 mm	67-3718

SHORT PERCH SADDLE

Pipe Size	Fraction	Decimal	Metric	Saddle P/N
1/8"	3/8"	.375"	9.53 mm	67-3719
		.391"	9.92 mm	67-3720
		.394"	10.00 mm	67-3721
		.400"	10.16 mm	67-3722
	13/32"	.406"	10.31 mm	67-3723
		.413"	10.50mm	67-3724
		.422"	10.72 mm	67-3725
		.430"	10.92 mm	67-3726
		.433"	11.00 mm	67-3727
	7/16"	.438"	11.13 mm	67-3728
	15/32"	.469"	11.91 mm	67-3729
		.472"	12.00 mm	67-3730
		.489"	12.42 mm	67-3731
	1/2"	.500"	12.70 mm	67-3732
		.512"	13.00 mm	67-3733
	17/32"	.531"	13.50 mm	67-3734
1/4"	9/16"	.540"	13.72 mm	67-3735
		.543"	13.80 mm	67-3736
		.547"	13.89 mm	67-3737
		.551"	14.00 mm	67-3738
	19/32"	.563"	14.30 mm	67-3739
		.591"	15.00 mm	67-3740
	5/8"	.594"	15.08 mm	67-3741
		.602"	15.29 mm	67-3742
		.625"	15.88 mm	67-3743
		.630"	16.00 mm	67-3744
	.641"	16.27 mm	67-3745	

SHORT PERCH SADDLE					
Pipe Size	Fraction	Decimal	Metric	Saddle P/N	
3/8"	21/32"	.656"	16.66 mm	67-3746	
		.669"	17.00 mm	67-3747	
		.675"	17.15 mm	67-3748	
		.677"	17.20 mm	67-3749	
		.681"	17.30 mm	67-3750	
	11/16"	.688"	17.48 mm	67-3751	
		.709"	18.00 mm	67-3752	
		23/32"	.718"	18.24 mm	67-3753
		3/4"	.750"	19.05 mm	67-3754
		25/32"	.781"	19.84 mm	67-3755
.787"	20.00 mm		67-3756		
.790"	20.07 mm		67-3757		
13/16"	.813"	20.65 mm	67-3758		
1/2"	27/32"	.840"	21.34 mm	67-3759	
		.844"	21.44 mm	67-3760	
		.854"	21.70 mm	67-3761	
		.859"	21.83 mm	67-3762	
		.866"	22.00 mm	67-3763	
	29/32"	.875"	22.23 mm	67-3764	
		.906"	23.00 mm	67-3765	
		15/16"	.938"	23.83 mm	67-3766
	31/32"	.969"	24.61 mm	67-3767	
		.984"	25.00 mm	67-3768	
1"	1.000"	25.40 mm	67-3769		
3/4"		1.050"	26.67 mm	67-3770	

10. TOOL BITS

10.1 Tube Squaring Tool Bits for Standard Saddles

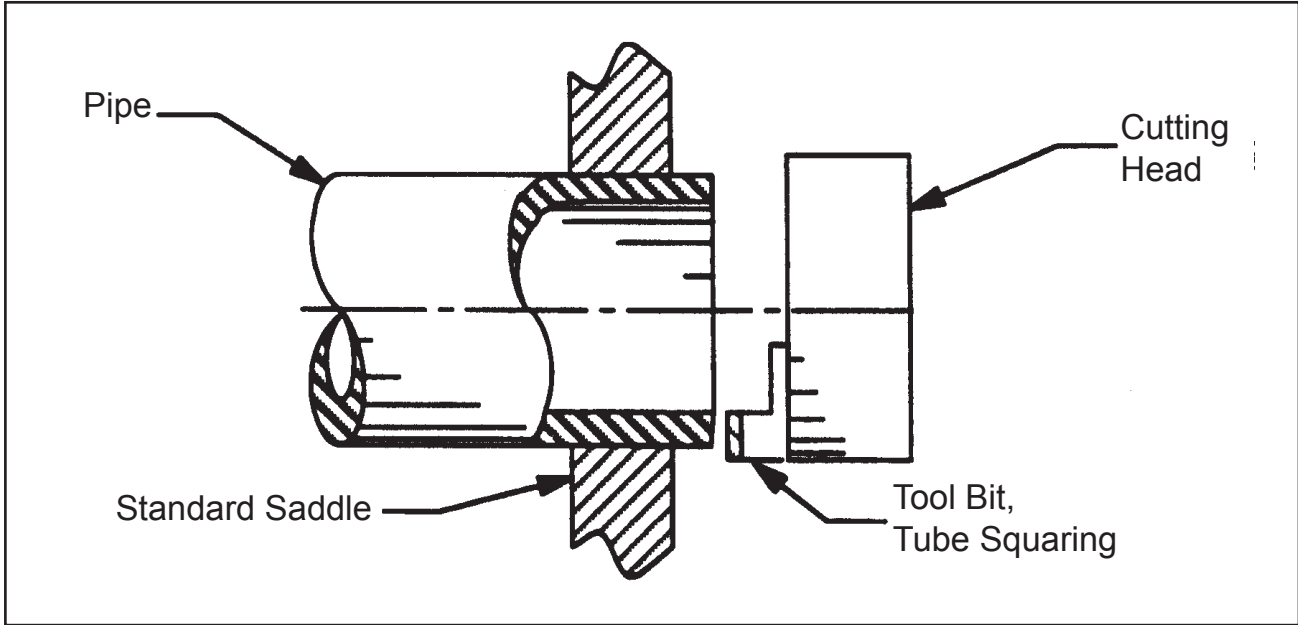

TUBE SQUARING TOOL BITS FOR STANDARD SADDLES

Range	Max Wall Thickness	Pipe or Tube Material	Tool Bit Height	Squaring Tool Bit P/N
.125" OD thru 1.05" OD (3.2mm OD thru 26.7mm OD)	.125" (3.2mm)	CS SS 316L SS	.750" (16.1mm)	Durabit 1

10.2 Tube Squaring Tool Bits for Short Perch Saddles

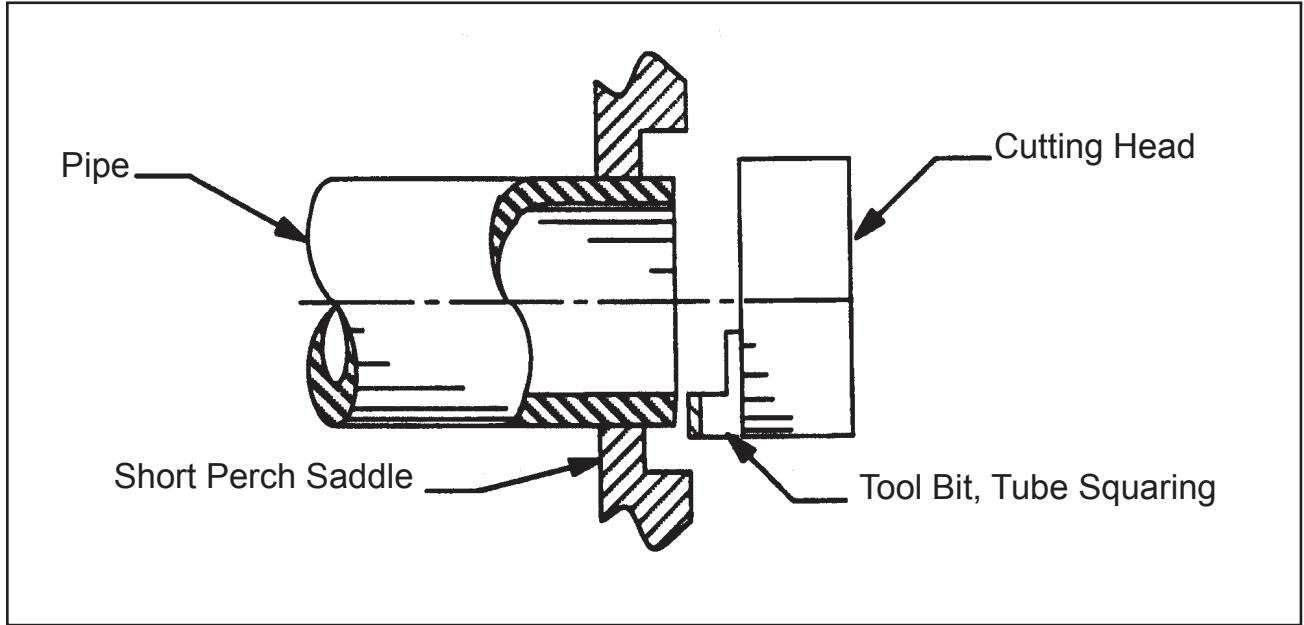

TUBE SQUARING TOOL BITS FOR STANDARD SADDLES

Range	Max Wall Thickness	Pipe or Tube Material	Tool Bit Height	Tool Bit Material	Squaring Tool Bit P/N
.125" OD thru 1.05" OD (3.2mm OD thru 26.7mm OD)	.125" (3.2 mm)	CS	1.160" (29.5mm)	M2	Durabit 3
		SS			99-5176
		316L		M2	99-0725
		SS			

11. TROUBLESHOOTING

Problem: Tool Bit Chatters

- The tool bit is loose or overextended.
 - The tool bit is damaged.
 - The tool holder is too loose in the slides.
 - The cutting speed is too fast.
 - The clamping pads are loose on the pipe or tube.
 - Cutting fluid is required.
 - The main bearing pre-load is loose.
-

Problem: Excessive Tool Bit Wear

- The pipe or tube material is too hard or abrasive.
 - The cutting speed is too fast.
 - Cutting fluid is required.
 - A dull Tool Bit is causing surface hardening conditions (Stainless pipe or tubing).
 - There is scale or other foreign matter on the pipe or tube, which is dulling the tool bit at the start of the cut.
 - The tool bit is incorrect for the material being cut.
-

Problem: Rough Surface Finish

- The tool bit is dull, chipped, etc.
 - Metal build-up on the cutting edge of the tool bit is creating a false cutting edge.
 - Cutting fluid is required.
 - The cutting speed is incorrect.
-

Problem: Tool Holder is not Feeding

- The feed pin is broken or out of position.
 - The feed sprocket shear pin is broken.
 - The feed screw is stripped.
 - The feed nut is stripped.
 - The slide rails are too tight.
-

Problem: Loss of Air Power

The air supply pressure is too low.
The air filter is plugged.
The air line size is insufficient.
The air line is too long.

Problem: Loss of Hydraulic Power

The hydraulic supply pressure is too low.
The hydraulic filter is plugged.
The hydraulic line size is insufficient.
The hydraulic line is too long.

Problem: Tool Bit does not Reach the Work

Incorrect tool blocks are installed for the size of the pipe or tube
Incorrect tool bit is installed.

Problem: Hydraulic Motor does not Star

The hydraulic power supply is shut off.
The hydraulic motor is damaged and will not run free.

12. ACCESSORIES

The following accessories are recommended for use with the Model 301SP Tube Squaring Machine and are available from TRI TOOL INC:

- Electric Foot Pedal
- Saddles
- Tool Bits
- Bench Top Stand (P/N 60-0022)
- Portable Air Filter (P/N 75-0115)
- A Filter/Regulator/Lubricator (FRL) is required to protect the warranty on all TRI TOOL INC air driven tools.
- Battery Charger Assy:
 - 110V Standard (30-6143)
 - 220V Optional (30-6144)

13. METABO SAFETY INSTRUCTIONS

Refer to the Metabo Cordless Drill/Driver Manual for all safety and operating procedures.

14. ILLUSTRATED PARTS BREAKDOWN

MODEL 301SP SUB-ASSEMBLY (P/N 02-2200)

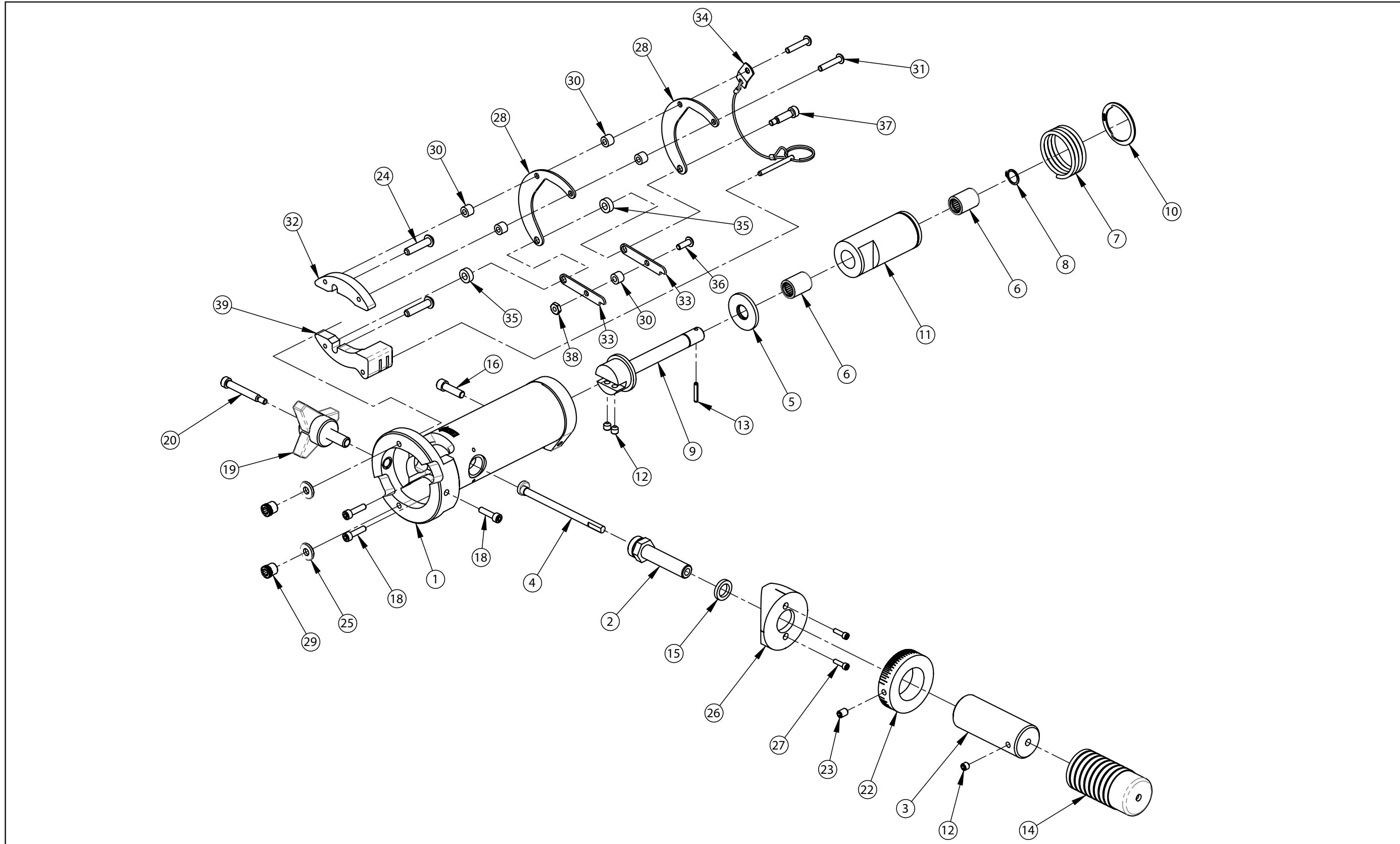

Parts List, Model 301SP Sub-Assembly (P/N 02-2200)

Item No.	Part No.	Description	Qty
1.	19-0736	HOUSING ASSY., 301SP	1
2.	46-0014	SLEEVE	1
3.	41-0018	HANDLE, 1.25" X 3.19"	1
4.	14-0006	SHAFT ASSY.	1
5.	34-0059	WASHER, FLAT, 1/2" X 1 3/8"	1
6.	29-0028	BEARING, ROLLER, 1/2" X 11/16" X 7/8"	2
7.	40-0035	SPRING, COMP., 1 11/16" X 1 3/4"	1
8.	30-0062	RING, RETAINING, EXT., 1/2" O.D.	1
9.	20-0016	SHAFT	1
10.	30-0063	RING, RETAINING, EXT., 1 3/8" O.D.	1
11.	46-0016	SLEEVE	1
12.	33-0499	SCREW, SET, 1/4 - 20 X 1/4", CUP PT.	3
13.	32-0026	PIN, ROLL, 1/8" DIA. X 3/4"	1
14.	30-2278	GRIP	1
15.	34-0060	WASHER, FLAT, 1/2" X 3/4" X 1/8"	1
16.	33-0041	SCREW, CAP, 1/4 - 20 X 7/8"	1
18.	33-0030	SCREW, CAP, #10 - 24 X 3/4"	3
19.	42-0146	KNOB ASSY., ADJUST	1
20.	33-1924	SCREW, SHOULDER, 1/4" X 1 1/2", 5/32", HEX	1
22.	46-0480	SLEEVE, INDICATOR	1
23.	33-0501	SCREW, SET, 1/4 - 20 X 3/8", CUP PT.	1
24.	33-4131	SCREW, BUTTON, 1/4 - 20 X 1 1/8"	2
25.	34-0304	WASHER, .265" I.D. X .750" O.D. X .090" THK.	2
26.	27-0614	ADAPTOR, INDICATOR	1
27.	33-0013	SCREW, CAP, #6 - 32 X 1/2"	2
28.	24-4554	PLATE, CHIP GUARD	2
29.	30-6428	INSERT NUT, 1/4 - 20	2
30.	30-6429	SPACER, 3/8" O.D. X 3/16" I.D. X 9/32"	5
31.	33-0316	SCREW, BUTTON, #10 - 32 X 1"	2
32.	48-4058	BLOCK, CHIP GUARD	1
33.	24-4555	PLATE, DOOR, CHIP GUARD	2
34.	30-6455	PIN, QUICK RELEASE W / LANYARD	1
35.	30-6456	SPACER, 1/2" X 3/16" X .252" I.D.	2
36.	33-4401	SCREW, BUTTON, #10 - 32 X 9/16"	1
37.	33-4402	SCREW, SHOULDER, MOD.	1
38.	35-0013	NUT, HEX, #10 - 32	1
39.	48-4119	BLOCK, HINGE, CHIP GUARD	1

ELECTRIC MOTOR ASSEMBLY

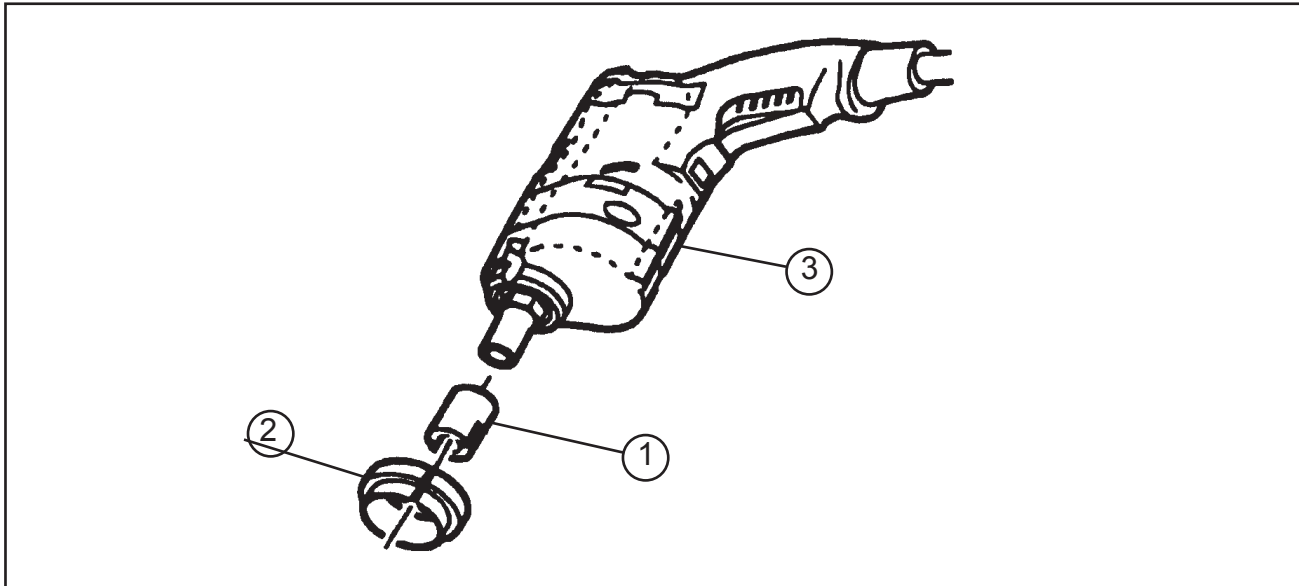

Parts List, Electric Motor Assembly

Item No.	Part No.	Description	Qty
1.	27-0018	ADAPT,DRIVE,ELEC	1
2.	27-0060	ADAPT,DRILL MOTOR	1
3.	58-0277	MOTOR,C.W.ELEC,METABO,110V	1
	33-3506	SCREW,SELF-TAPPING,#4 X 3/8"LG	1
	58-0274	MOTOR,ELECTRICAL,METABO 110V	1
3.	58-0323	MOTOR, MOD., ELECTRIC, 220V	1
	46-0750	SLEEVE, MOTOR HOUSING	1
	58-0006	MOTOR,ELEC,BOSCH 220V	1
	30-4934	UK TO EU ADAPTER,10 AMP,250V	1
1.	27-0018	ADAPT,DRIVE,ELEC	1
2.	27-0060	ADAPT,DRILL MOTOR	1
3.	58-0331	MOTOR, MOD., 100V MAKITA, JAPAN	1
	58-0330	MOTOR,ELEC, MAKITA,100V,JAPAN	1
	46-0796	SLEEVE, MOTOR HOUSING	1
2.	27-0060	ADAPT,DRILL MOTOR	1
1.	27-1541	ADAPTER,DRIVE,ELEC,301,JAPAN	1
3.	58-0317	MOTOR,CORDLESS,18V,METABO,MOD CW	1
	32-0097	PIN,ROLL,3/32 DIA X 3/8	1

	58-0314	MOTOR,CORDLESS,18V,METABO,120V	1
2.	27-1561	ADAPTER, SLEEVE	1
1.	27-1562	ADAPTER, DRIVE	1
3.	58-0354	MOTOR ASSY., CORDLESS, 18V, JAPAN	1
1.	27-1315	ADAPTER	1
2.	27-1591	ADAPTER, MOTOR, CORDLESS, JAPAN	1
	33-0041	SCREW,CAP,1/4-20 X 7/8	1
	58-0353	MOTOR, CORDLESS, BRUSHLESS, JAPAN, MOD	1
	58-0351	MOTOR, CORDLESS, DEWALT, 100V,JAPAN	1

AIR MOTOR ASSEMBLY

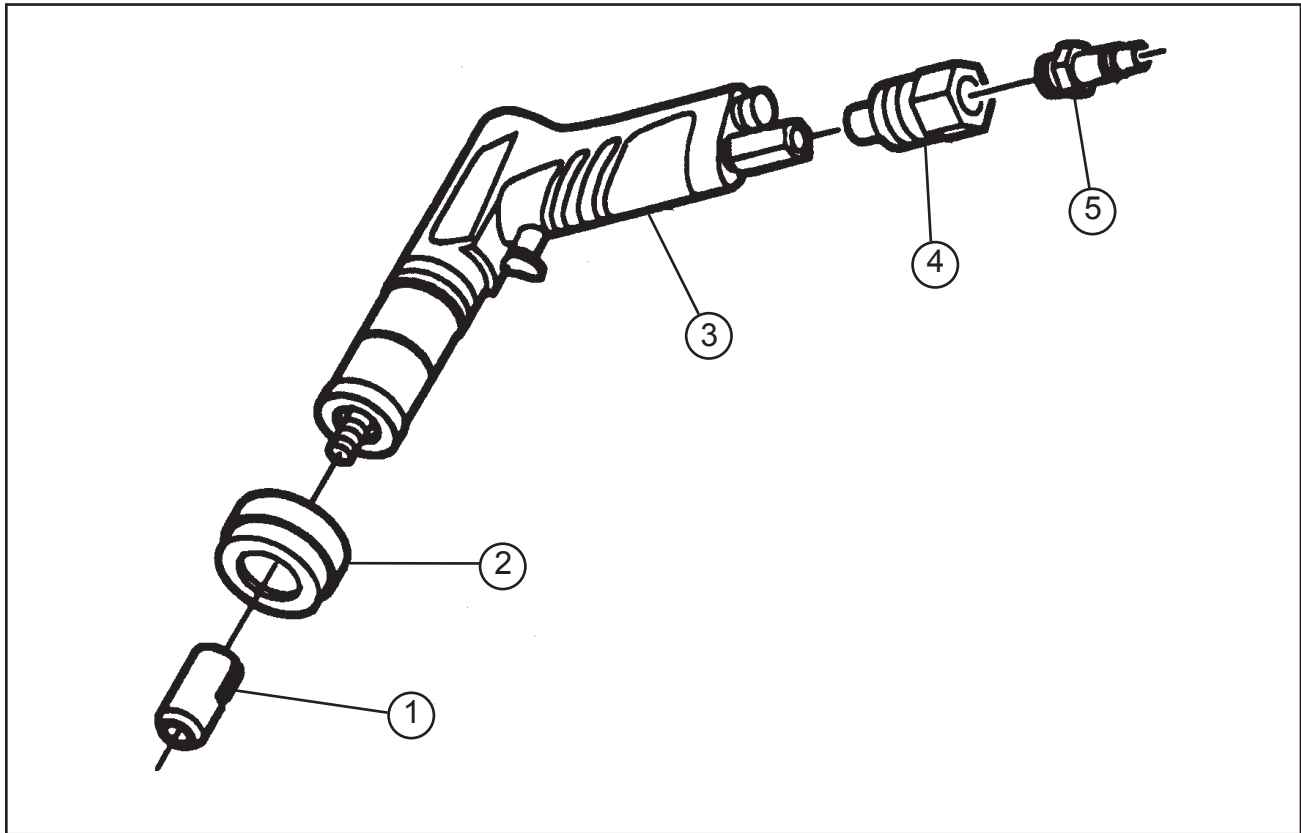

Parts List, Air Motor Assembly

Item No.	Part No.	Description	Qty
	57-0199	AIR MOTOR ASSY	1
1.	27-0019	ADAPTER	1
2.	46-0377	SLEEVE	1
3.	57-0198	AIR MOTOR	1
4.	53-0045	VALVE, FLOW CONTROL	1
5.	54-0149	COUPLING, MALE, QD	1

MOTOR ASSEMBLY, CORDLESS, 18V, METABO (P/N 58-0361)

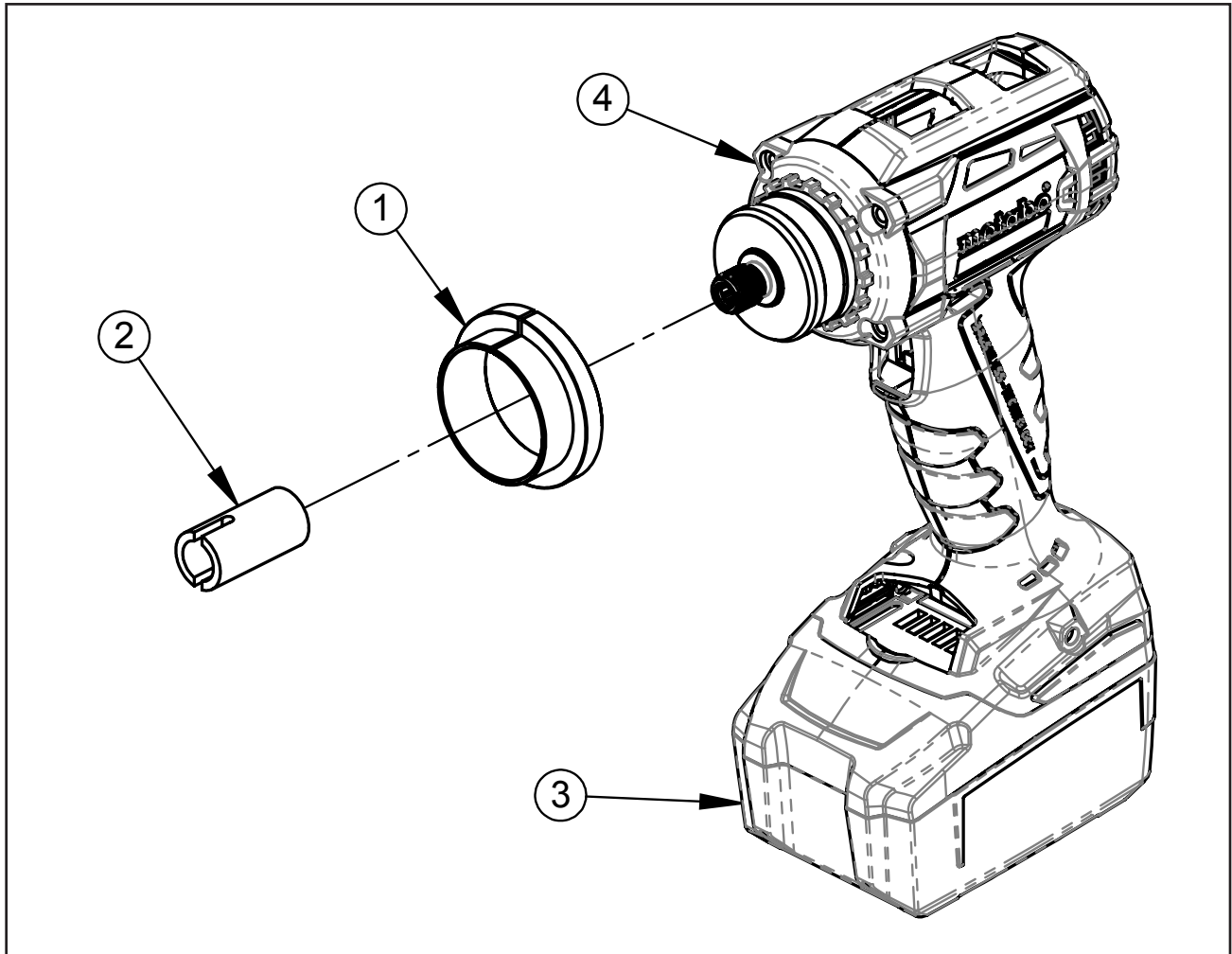

Parts List, Motor Assembly, Cordless, 18V, Metabo (P/N 58-0361)

Item No.	Part No.	Description	Qty
1.	27-1561	ADAPTER, SLEEVE	1
2.	27-1562	ADAPTER, DRIVE	1
3.	30-6142	BATTERY, METABO, 18V 5.2AH	1
4.	58-0317	MOTOR, CORDLESS, 18V, METABO	1
	NOT SHOWN		
	30-6143	CHARGER, METABO, 18V 5.2AH, 120V	1

MOUNTING BASE ASSEMBLY (P/N 60-0022)

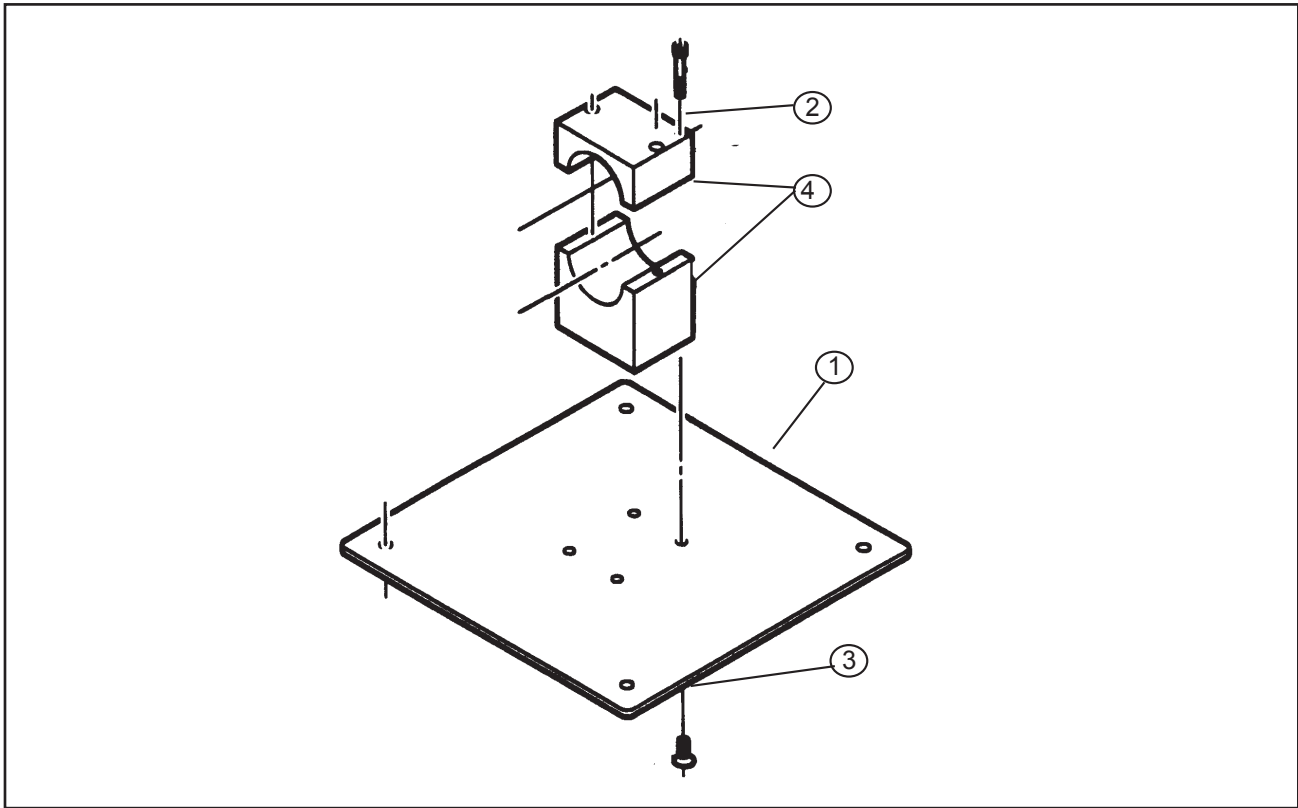

Parts List, Mounting Base Assembly (P/N 60-0022)

Item No.	Part No.	Description	Qty
1	24-0326	PLATE, RETAINING	1
2	33-0045	SCREW, CAP, 1/4-20 X 1 3/4"	2
3	33-0369	SCREW, FLAT, 5/16-18 X 3/4"	4
4	48-0173	BLOCK, RETAINING	1
	NOT SHOWN		
	36-0007	WRENCH, L, 5/32" HEX	1
	36-0008	WRENCH, L, 3/16" HEX	1
	36-0010	WRENCH, L, 1/4" HEX	1

CHIP GUARD KIT, 301SP (P/N 05-1431)

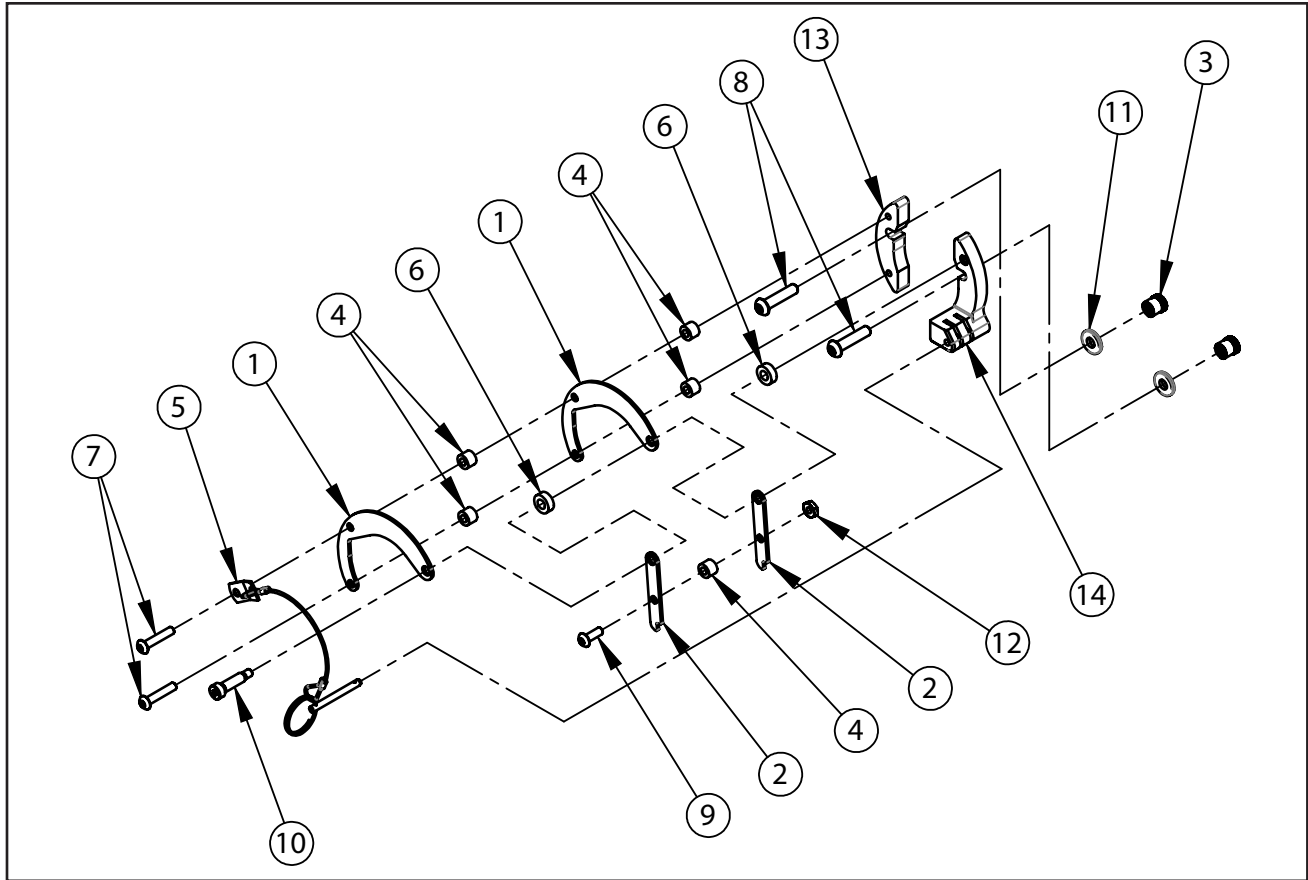

Parts List, Chip Guard Kit, 301SP (P/N 05-1431)

Item No.	Part No.	Description	Qty
1.	24-4554	PLATE, CHIP GUARD	2
2.	24-4555	PLATE, DOOR, CHIP GUARD	2
3.	30-6428	INSERT NUT, 1/4 - 20	2
4.	30-6429	SPACER, 3/8" O.D. X 3/16" I.D. X 9/32"	5
5.	30-6455	PIN, QUICK RELEASE W / LANYARD	1
6.	30-6456	SPACER, 1/2" X 3/16" X .252" I.D.	2
7.	33-0316	SCREW, BUTTON, #10 - 32 X 1"	2
8.	33-4131	SCREW, BUTTON, 1/4 - 20 X 1 1/8"	2
9.	33-4401	SCREW, BUTTON, #10 - 32 X 9/16"	1
10.	33-4402	SCREW, SHOULDER, MOD.	1
11.	34-0304	WASHER, .265" I.D. X .750" O.D. X .090" THK.	2
12.	35-0013	NUT, HEX, #10 - 32	1
13.	48-4058	BLOCK, CHIP GUARD	1
14.	48-4119	BLOCK, HINGE, CHIP GUARD	1



WARNING



Read the manual and be familiar with all safety precautions before operating equipment. The following are general warnings for industrial equipment with moving parts. Refer to the manual for specific warnings applicable to your equipment.



EYE HAZARD - Always wear appropriate eye protection while operating the equipment.



PINCH HAZARD - Keep your hands and clothing away from moving parts.



CRUSH HAZARD - The machinery, pipe, or work piece can shift, separate, lurch, or fall.



CHIP HAZARD - Metal chips may be hot and sharp. Be careful when you clear the tooling path or clean up chips.



TIE DOWN HAZARD - Deliberate overriding of safety triggers can result in serious injury. Never lock or tie down any safety triggers.



SHOCK HAZARD - Ensure that the equipment is properly installed and grounded. Ensure that the equipment is not damaged and that the power cord is intact.

OTHER HAZARDS

- Tool bits are sharp and can cause serious injury.
- Do not defeat or modify safety features.
- Disconnect power sources before servicing or moving the equipment.
- Remove all loose articles of clothing and jewelry before operating the equipment.

Be Safety Conscious!



3041 Sunrise Blvd.
Rancho Cordova, CA 95742
+1(916) 288-6100 • +1(800) 345-5015
www.tritool.com