



TECHNICAL SPECIFICATION MODEL 300STS-2 SHORT PERCH TUBE FACING AND SQUARING TOOL

The 300STS-2 (Small Tube System) Tube Squaring Tool is designed specifically to prepare tube for autogenous welding. The 300STS-2 will face .188" (4.8mm) to 2.500" (63.5mm) outside diameter tubing with a wall thickness up to .20" (5.0mm). The 300STS-2 uses an OD saddle clamping system for holding and rounding the tube. The 300STS-2 accepts its own torque through the saddle clamping system. The standard saddle clamping system requires a straight length of tube .875" (22.2mm) long. The Short Perch saddle clamping system requires a straight length of tube .19" (4.8mm) long. Speed is controlled by a variable speed electric motor. Feed is actuated by rotating an inline feed collar.

Design and Operating Features

- The Model 300STS-2 is lightweight and easy to handle
- Variable speed brushless cordless electric motors
- Variable speed corded electric motors
- Standard and short perch saddle clamps
- The cutting head accepts Squaring Tool Bits.
- The 300STS-2 accepts its own torque through the saddle clamping system
- Integral chip guards
- Inline feed with .20" (5.0mm) of travel
- Carrying Case
- Operator's Manual

Accessories (Optional)

- Bench Stand Assembly

Specifications

Pipe Cutting Capacities

Basic Pipe Sizes

- 1/8" All schedules
- 1/4" All schedules
- 3/8" All schedules
- 1/2" Schedules 5 through 160
- 3/4" Schedules 5 through 80
- 1" Schedules 5 through 80
- 1 1/4" Schedules 5 through 80
- 1 1/2" Schedules 5 through 80

- 2" Schedules 5 through 40

Basic Tube Sizes

.188" (4.8mm) through 2.500" (63.5mm) with wall thickness up to .200" (5.1mm)

Material Cutting Capabilities

- Chrome steels (20% max)
- Stainless steel
- Copper-nickel alloys and Aluminum without limitations except size and wall thickness
- Carbon steel
- Copper

Clearance and Dimensions

Reference Drawing No. 77-1859 & No. 77-1860

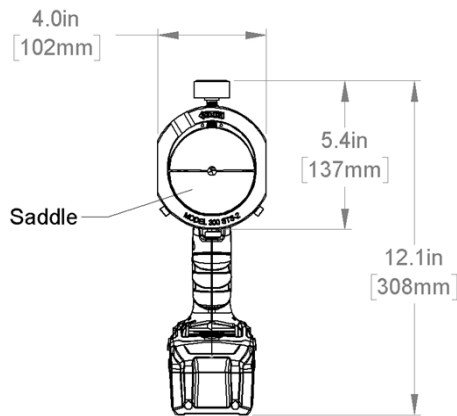

Figure 1. 77-1859 (Model 300STS-2 Cordless Metabo)

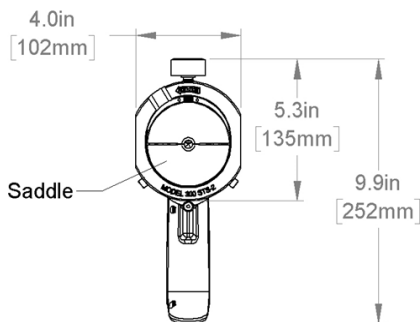
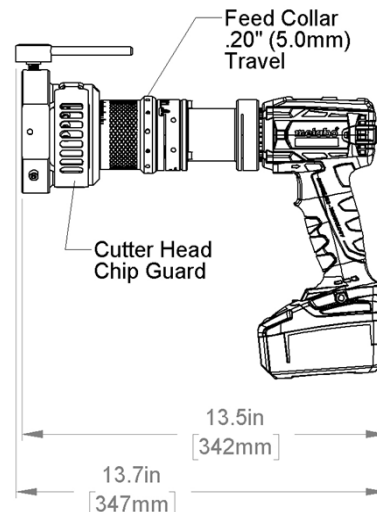
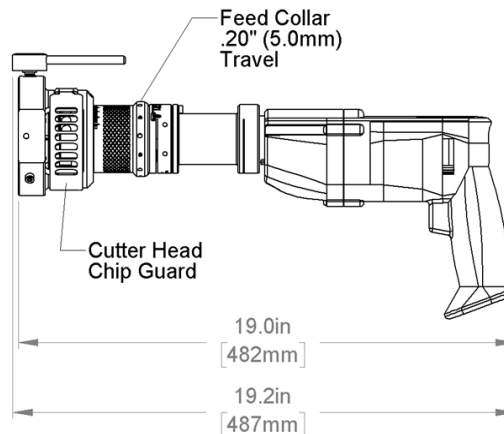

Figure 2. 77-1860 (Model 300STS-2 Corded 110V & 220V Metabo)



Drive Motor Options

- 18VDC Metabo Brushless Cordless Motor Assembly with 110VAC Charger
- 18VDC Metabo Brushless Cordless Motor Assembly with 220VAC Charger
- 110VAC 50/60 Hz 9.6 Amp Metabo Corded Motor Assembly
- 220VAC 50/60 Hz 4.8 Amp Metabo Corded Motor Assembly
- 100VAC 50/60 Hz 7.2 Amp Makita Corded Motor Assembly (For Japan Only)
- 18VDC Dewalt Brushless Cordless Motor Assembly (For Japan Only)

Weight

- Base machine 6.1 lbs. (2.8 Kg)
- Cordless Metabo Motor 4.2 lbs. (1.9 Kg)
- Corded Metabo Motor 5.6 lbs. (2.5 Kg)
- Corded Makita Motor (Japanese Version) 5.3 lbs. (2.4 Kg)
- Cordless Dewalt Mtr (Japanese Version) 4.0 lbs. (1.8 Kg)

Note To The Customer

Spare Parts and Standard Tool Bits are available from stock. Engineering design services for custom tool bits and special function modifications are available from the factory.

All Tri Tool and allied equipment products are subject to design improvements and specification changes at any time with no obligation to units already sold.

Warranty (limited): Parts and equipment are warranted against defects in material and workmanship for a period of one (1) year from date of purchase. Full details supplied on request and/or with the tools.



www.tritool.com



@tritooltechnologies



@tritooltech



@tritooltechnologies



3041 Sunrise Blvd,
Rancho Cordova,
CA 95742
+1-916-288-6100
+1-800-345-5015
Fax 916-288-6160

Copyright © Proprietary property of Tri Tool Inc. No reproduction, use or duplication of the information shown hereon is permitted without the express written consent of Tri Tool Inc.